

AMI SERVICE INFORMATION BINDER

INDEX

SERVICE BULLETINS AND LETTERS

Service Bulletins (Starting with Bulletin No. 176)

SERVICE MANUALS - RECORD CHANGERS

Record Changer Service Manual (Models 900, 900-1, 950 & 960)  
Record Changer Service Manual (Models 900, 900-1, 950, 960, 985, 990)  
RCS (Continental 2)

SERVICE MANUALS - CREDIT & SELECTION SYSTEM

Model I-100 & 200-M Credit & Selection System Service Manual  
Model J Credit & Selection System Service Manual (Manual & Electric Selection)  
\* R-1473 Credit Unit & Pricing System Service Manual  
R-1855 & R-2358 Automatic Selectors Service Manual  
SSS (Continental 2)

SERVICE MANUALS - SOUND SYSTEM

SSM (Continental 2)

SERVICE MANUALS - AUXILIARY EQUIPMENT

AE (Continental 2)  
AMI Automix 45-33 Service Data

PARTS CATALOGS - CABINETS

Model H Cabinets & Components Parts Catalog  
Model I Cabinets & Components Parts Catalog  
Model J Cabinets & Components Parts Catalog  
Model K Cabinets & Components Parts Catalog  
Continental & Lyric Cabinets & Components Parts Catalog  
CP (Continental 2)

PARTS CATALOGS - RECORD CHANGERS

Record Changer Parts Catalog (Models 900, 900-1, 950 & 960)  
Record Changer Parts Catalog (Models 900, 900-1, 950, 960, 985 & 990)  
RCP (Continental 2)

PARTS CATALOGS - CREDIT & SELECTION SYSTEM

Models H & I Credit & Selection System Components Parts Catalog  
Model K Credit & Selection System Components Parts Catalog  
SPC (Continental 2)

PARTS CATALOGS - SOUND SYSTEM

Models H & I Sound System Components Parts Catalog  
Model K Sound System Components Parts Catalog (will also include  
Continental and Lyric)  
SSP (Continental 2)

PARTS CATALOGS - AUXILIARY EQUIPMENT

- ✓ Sound System Accessories
- Standard Parts

PARTS CATALOGS - WALL BOXES

Wall Boxes Parts Catalog (WQ-200, 120, 200-1 and 200-3)

CONTINENTAL 2 - SERVICE MANUAL AND PARTS CATALOG

- CM - Cabinet Maintenance Manual
  - CP - Cabinet and Components Parts Catalog
  - RCS - Record Changer Service Manual
  - RCP - Record Changer Parts Catalog
  - SSS - Selector and Search Unit Service Manual
  - SPC - Credit Unit, Selector and Search Unit Parts Catalog
    - \* - R-1473 Credit Unit and Pricing System
  - SSM - Sound System Service Manual
  - SSP - Sound System Parts Catalog
  - AE - Auxiliary Equipment
    - AMI Automix 45-33 Service Date (thru p. AE-8)
- 
- ✓ Sound System Accessories
  - Standard Parts (from p. AE-9)

ROWE-AC SERVICE INFORMATION BINDER - Book III

- INDEX -

SERVICE BULLETINS and LETTERS

Service Bulletins (Starting with Bulletin No. 188)

GENERAL PHONOGRAPH INFORMATION

CONTINENTAL 2 Foreword

CONTINENTAL 2, 200 Selection Specifications

CONTINENTAL 2, 100 Selection Specifications

CONTINENTAL 2 Manual Contents Sheet (Back page - Unpacking Instructions)

CONTINENTAL 2 Cabinet Maintenance Manual Section

ROWE-AMI Warranty and Foreword

ROWE-AMI Phonograph Specifications

ROWE-AMI General Phonograph Information (Includes Cycle of Operation and Trouble Shooting Chart)

SERVICE MANUALS - RECORD CHANGERS

CONTINENTAL 2 Record Changer Service Manual (Also covers: Model K, LYRIC and CONTINENTAL 1)

Model 1100 Record Changer Service Manual (ROWE-AMI)

SERVICE MANUALS - CREDIT and SELECTION SYSTEM

R-1473 Credit Unit and Pricing System Service Manual (Model K, LYRIC, CONTINENTAL 1 and 2)

R-1865-E Selector and R-2405 Search Unit Service Manual (CONTINENTAL 2)

ROWE-AMI Selection System Service Manual

ROWE-AMI Credit Unit and Pricing System Service Manual

SERVICE MANUALS - SOUND SYSTEM

CONTINENTAL 2 Sound System Service Manual

ROWE-AMI Sound System Service Manual

SERVICE MANUALS - AUXILIARY EQUIPMENT

CONTINENTAL 2 Auxiliary Equipment

SERVICE MANUALS - Wall Boxes

WQ-200 and WQ-120 Wall Box Service Manual (WQ-120, WQ-200, WQ-200-1, WQ-200-2, and WQ-200-3)

PARTS CATALOGS - CABINETS

CONTINENTAL 2 Cabinet and Components Parts Catalog

ROWE-AMI Cabinet and Components Parts Catalog (Includes - STEREO ROUND Sound System Components)

PARTS CATALOGS - RECORD CHANGERS

CONTINENTAL 2 Record Changer Parts Catalog  
Model 1100 Record Changer (ROWE-AMI)

PARTS CATALOGS - CREDIT and SELECTION SYSTEM

CONTINENTAL 2 Credit Unit, Selector and Search Unit Parts Catalog  
ROWE-AMI Selector and Credit Unit Parts Catalog

PARTS CATALOGS - SOUND SYSTEM

CONTINENTAL 2 Sound System Parts Catalog  
\*\*ROWE-AMI Sound System Components will be found in the ROWE-AMI  
Cabinet and Components Parts Catalog

PARTS CATALOGS - AUXILIARY EQUIPMENT

Sales Catalog (Phonographs, Equipment and Accessories - SC-1)  
Wall Box Stepper Manual and Parts Catalog (Model CCA, CCB, CCC and CCD)  
ROWE-AMI Standard Hardware Catalog

PARTS CATALOGS - WALL BOXES

WQ-200 and WQ-120 Wall Box Parts Catalog (Model WQ-120, WQ-200, WQ-200-1,  
WQ-200-2 and WQ-200-3)

\*\* Sound System Parts Catalog section composed of plate numbers 13, 14, and 15 of the  
phonograph parts catalog. These three plates may be relocated to Parts Catalog - Sound  
System section of this binder if so desired.

# SERVICE BULLETIN

## AUTOMATIC MUSIC, INC.

1500 UNION AVENUE, S. E., GRAND RAPIDS 2, MICHIGAN • TELEPHONE CHERRY 3-3633

# AMI

November 18, 1959

BULLETIN NO. 176

Model "K"

*file  
A.M.D.*

**SUBJECT:** Adjustments for the Model "K" Record Changer

The new AC transfer motor and new camshaft switches used on Model "K" record changers make new adjustment techniques necessary. The following procedures will make the adjustments easy.

Before adjusting any camshaft switch, make sure the transfer motor is in the right position. Check as follows.

With the gripper bow over the turntable, turn the camshaft until the crank on the transfer motor and the sector gear link are in line.

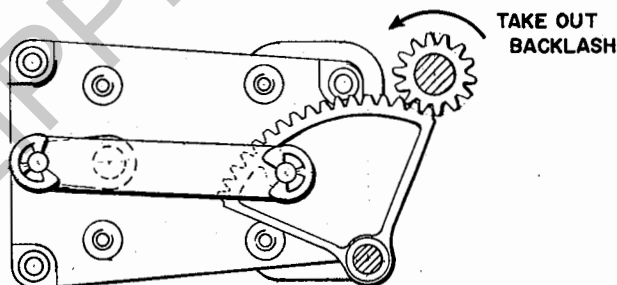

FIG. 1

The tone arm cam and the cam follower plate should be in the relationship shown in Figure 2.

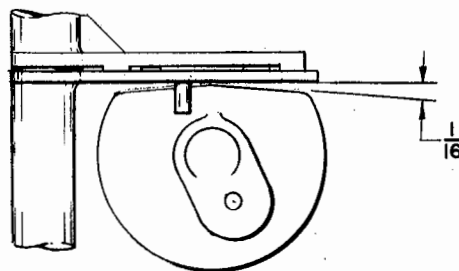

FIG. 2

SINCE 1909 DESIGNERS, ENGINEERS AND MANUFACTURERS OF AUTOMATIC MUSICAL INSTRUMENTS FOR BUSINESS AND INDUSTRY

AFFILIATE OF *AUTOMATIC*  
CANTEEN COMPANY OF AMERICA

Slide the transfer motor forward or backward until the cam is in the position shown. Make a selection and check the cam. Make sure the gripper shoes are fully retracted at both extremes of the transfer cycle. If the shoes are not fully retracted when the gripper bow is over the record magazine, shift the transfer motor slightly to the rear. Make sure the motor mounting screws and the set screw in the driven gear are tight. With the gripper bow over the record magazine, turn the camshaft until the crank on the transfer motor shaft and the sector gear link form a straight line.

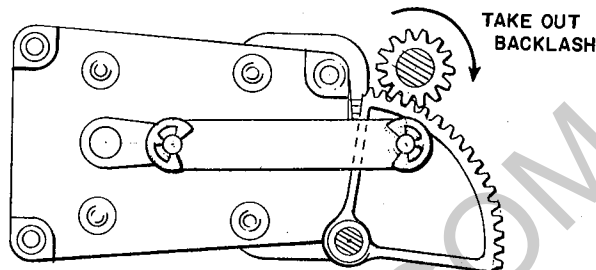

FIG. 3

Unplug the transfer motor. Back out all camshaft switch adjusting screws several turns. Trip the scan control.

Turn #1 screw in slowly until the turntable stops and then turn the screw in exactly one turn more.

Turn #2 screw in slowly until the record magazine motor starts and then turn the screw in exactly one turn more.

Plug a test light - a service light or the light on a soldering gun will do - into the "transfer motor" socket. Turn screw #3 in until the light goes out and then turn it in exactly  $3/4$  turn more.

Trip the even stopping switch. Turn #4 screw in slowly until the toggle shifts and then turn the screw in one turn more.

Release the even stopping switch and trip the odd stopping switch. Turn screw #5 in slowly until the toggle shifts and then turn the screw in one turn more.

With the gripper bow over the turntable, turn the camshaft until the crank on the transfer motor and the sector gear link are in line. (See Figure 1)

Trip either stopping switch and turn #6 screw in slowly until the reset solenoid operates. Then turn the screw in one turn more.

Remove the test light and plug in the transfer motor.

# SERVICE BULLETIN

## AUTOMATIC MUSIC, INC.

1500 UNION AVENUE, S. E., GRAND RAPIDS 2, MICHIGAN • TELEPHONE CHERRY 3-3633

# AMI

November 18, 1959

### BULLETIN NO. 176

#### Model "K"

**SUBJECT:** Adjustments for the Model "K" Record Changer

The new AC transfer motor and new camshaft switches used on Model "K" record changers make new adjustment techniques necessary. The following procedures will make the adjustments easy.

Before adjusting any camshaft switch, make sure the transfer motor is in the right position. Check as follows.

With the gripper bow over the turntable, turn the camshaft until the crank on the transfer motor and the sector gear link are in line.

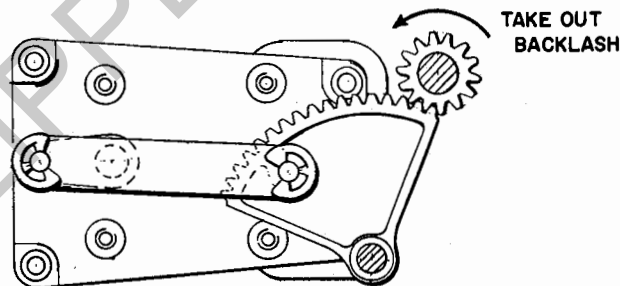

FIG. 1

The tone arm cam and the cam follower plate should be in the relationship shown in Figure 2.

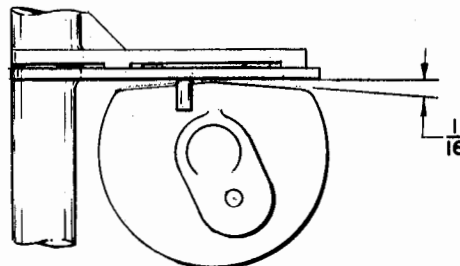

FIG. 2

SINCE 1909 DESIGNERS, ENGINEERS AND MANUFACTURERS OF AUTOMATIC MUSICAL INSTRUMENTS FOR BUSINESS AND INDUSTRY

AFFILIATE OF *AUTOMATIC*  
CANTEEN COMPANY OF AMERICA

Slide the transfer motor forward or backward until the cam is in the position shown. Make a selection and check the cam. Make sure the gripper shoes are fully retracted at both extremes of the transfer cycle. If the shoes are not fully retracted when the gripper bow is over the record magazine, shift the transfer motor slightly to the rear. Make sure the motor mounting screws and the set screw in the driven gear are tight. With the gripper bow over the record magazine, turn the camshaft until the crank on the transfer motor shaft and the sector gear link form a straight line.

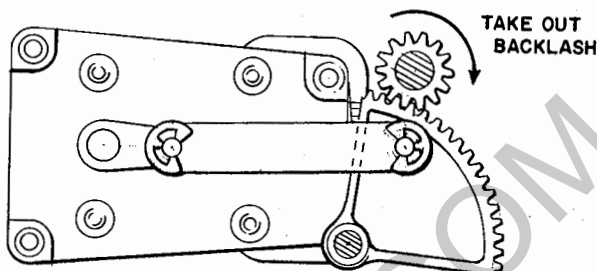

FIG. 3

Unplug the transfer motor. Back out all camshaft switch adjusting screws several turns. Trip the scan control.

Turn #1 screw in slowly until the turntable stops and then turn the screw in exactly one turn more.

Turn #2 screw in slowly until the record magazine motor starts and then turn the screw in exactly one turn more.

Plug a test light - a service light or the light on a soldering gun will do - into the "transfer motor" socket. Turn screw #3 in until the light goes out and then turn it in exactly  $3/4$  turn more.

Trip the even stopping switch. Turn #4 screw in slowly until the toggle shifts and then turn the screw in one turn more.

Release the even stopping switch and trip the odd stopping switch. Turn screw #5 in slowly until the toggle shifts and then turn the screw in one turn more.

With the gripper bow over the turntable, turn the camshaft until the crank on the transfer motor and the sector gear link are in line. (See Figure 1)

Trip either stopping switch and turn #6 screw in slowly until the reset solenoid operates. Then turn the screw in one turn more.

Remove the test light and plug in the transfer motor.



# SERVICE BULLETIN

**AUTOMATIC MUSIC, INC.**

1500 UNION AVENUE, S. E., GRAND RAPIDS 2, MICHIGAN • TELEPHONE CHERRY 3-3633

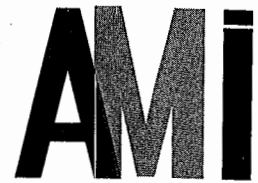
The logo for Automatic Music, Inc. (AMI) consists of the letters 'A', 'M', and 'i' in a bold, sans-serif font. The 'i' has a horizontal bar at the top, resembling a stylized 'i' or a lowercase 'l'.

January 22, 1960

BULLETIN NO. 177

Model "K"

SUBJECT: Amplifier Tubes

The tube originally designated 12AX7 is now produced in three versions: 12AX7, ECC83, and 7025. All have the same general characteristics and circuit connections.

The 12AX7 is a standard general-purpose tube. The ECC83 and 7025 are high quality tubes built to more rigid specifications than the 12AX7. The ECC83 is of European manufacture while the 7025 is made by RCA.

The European tubes are usually marked "ECC83/12AX7". This means that the tube is an ECC83 but it can be used in applications calling for a 12AX7.

Any circuit that specifies a 12AX7 can use a 7025 or an ECC83. 7025's and ECC83's can be used in circuits calling for either type. 12AX7's should not be used where the 7025 or ECC83 is specified.

The input stage of our new amplifier requires a 7025 or an ECC83. All other stages can use general purpose tubes. In practice, we use ECC83's throughout.

For replacement purposes, ordinary 12AX7's can be used in those sockets marked "ECC83/12AX7". The input stages - the shielded tubes - must have ECC83's or 7025's.

APPLICATIONS ENGINEERING

CLE/hr

SINCE 1909 DESIGNERS, ENGINEERS AND MANUFACTURERS OF AUTOMATIC MUSICAL INSTRUMENTS FOR BUSINESS AND INDUSTRY

AFFILIATE OF  **AUTOMATIC**  
CANTEN COMPANY OF AMERICA

# SERVICE BULLETIN

## AUTOMATIC MUSIC, INC.

1500 UNION AVENUE, S. E., GRAND RAPIDS 2, MICHIGAN • TELEPHONE CHERRY 3-3633

# AMi

November 18, 1959

BULLETIN NO. 176

Model "K"

**SUBJECT:** Adjustments for the Model "K" Record Changer

The new AC transfer motor and new camshaft switches used on Model "K" record changers make new adjustment techniques necessary. The following procedures will make the adjustments easy.

Before adjusting any camshaft switch, make sure the transfer motor is in the right position. Check as follows.

With the gripper bow over the turntable, turn the camshaft until the crank on the transfer motor and the sector gear link are in line.

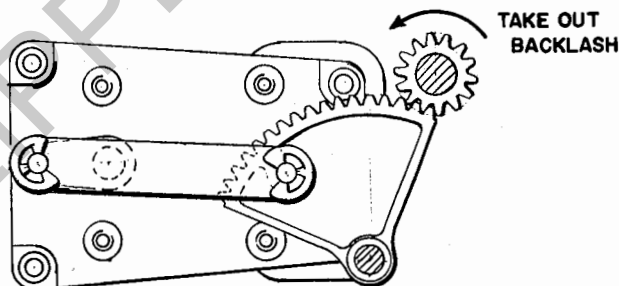

FIG. 1

The tone arm cam and the cam follower plate should be in the relationship shown in Figure 2.

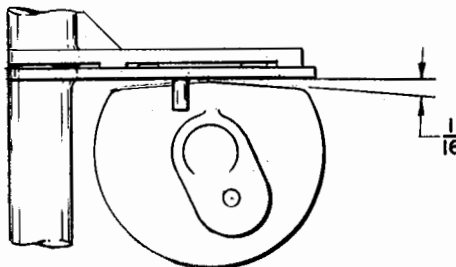

FIG. 2

SINCE 1909 DESIGNERS, ENGINEERS AND MANUFACTURERS OF AUTOMATIC MUSICAL INSTRUMENTS FOR BUSINESS AND INDUSTRY

AFFILIATE OF *Automatic*  
CANTEN COMPANY of AMERICA

Slide the transfer motor forward or backward until the cam is in the position shown. Make a selection and check the cam. Make sure the gripper shoes are fully retracted at both extremes of the transfer cycle. If the shoes are not fully retracted when the gripper bow is over the record magazine, shift the transfer motor slightly to the rear. Make sure the motor mounting screws and the set screw in the driven gear are tight. With the gripper bow over the record magazine, turn the camshaft until the crank on the transfer motor shaft and the sector gear link form a straight line.

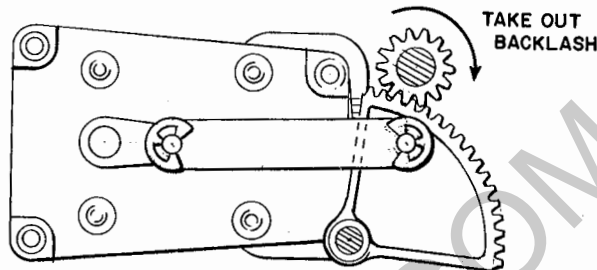

FIG. 3

Unplug the transfer motor. Back out all camshaft switch adjusting screws several turns. Trip the scan control.

Turn #1 screw in slowly until the turntable stops and then turn the screw in exactly one turn more.

Turn #2 screw in slowly until the record magazine motor starts and then turn the screw in exactly one turn more.

Plug a test light - a service light or the light on a soldering gun will do - into the "transfer motor" socket. Turn screw #3 in until the light goes out and then turn it in exactly  $3/4$  turn more.

Trip the even stopping switch. Turn #4 screw in slowly until the toggle shifts and then turn the screw in one turn more.

Release the even stopping switch and trip the odd stopping switch. Turn screw #5 in slowly until the toggle shifts and then turn the screw in one turn more.

With the gripper bow over the turntable, turn the camshaft until the crank on the transfer motor and the sector gear link are in line. (See Figure 1)

Trip either stopping switch and turn #6 screw in slowly until the reset solenoid operates. Then turn the screw in one turn more.

Remove the test light and plug in the transfer motor.

# SERVICE BULLETIN

## AUTOMATIC MUSIC, INC.

1500 UNION AVENUE, S. E., GRAND RAPIDS 2, MICHIGAN • TELEPHONE CHERRY 3-3633

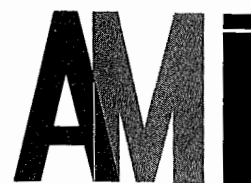

January 22, 1960

BULLETIN NO. 177

Model "K"

SUBJECT: Amplifier Tubes

The tube originally designated 12AX7 is now produced in three versions: 12AX7, ECC83, and 7025. All have the same general characteristics and circuit connections.

The 12AX7 is a standard general-purpose tube. The ECC83 and 7025 are high quality tubes built to more rigid specifications than the 12AX7. The ECC83 is of European manufacture while the 7025 is made by RCA.

The European tubes are usually marked "ECC83/12AX7". This means that the tube is an ECC83 but it can be used in applications calling for a 12AX7.

Any circuit that specifies a 12AX7 can use a 7025 or an ECC83. 7025's and ECC83's can be used in circuits calling for either type. 12AX7's should not be used where the 7025 or ECC83 is specified.

The input stage of our new amplifier requires a 7025 or an ECC83. All other stages can use general purpose tubes. In practice, we use ECC83's throughout.

For replacement purposes, ordinary 12AX7's can be used in those sockets marked "ECC83/12AX7". The input stages - the shielded tubes - must have ECC83's or 7025's.

APPLICATIONS ENGINEERING

CLB/hr

# SERVICE BULLETIN

**AUTOMATIC MUSIC, INC.**

1500 UNION AVENUE, S. E., GRAND RAPIDS 2, MICHIGAN • TELEPHONE CHERRY 3-3633

# AMI

January 21, 1960

BULLETIN NO. 178

Model "K"

SUBJECT: Color Code for Molded Tubular Capacitors

One of our major suppliers of capacitors, Sprague Products Company, is now furnishing molded tubular capacitors identified by colored bands instead of printed values. Other manufacturers may well follow Sprague's lead.

Because of this trend, we have prepared the enclosed chart which explains the color code used for molded tubular capacitors. This system does not apply to other types of capacitors.

APPLICATIONS ENGINEERING

CLB/hr  
Attach.

COLOR	FIRST NUMBER 1st BAND	SECOND NUMBER 2nd BAND	MULTIPLIER 3rd BAND		TOLERANCE 4th BAND	VOLTAGE RATING		COLOR
			(MMFD)	(MFD)		5th BAND	6th BAND	
No Band	—	—	---	---	---	—	00	No Band
Black	—	0	---	---	±20%	—	—	Black
Brown	1	1	XX0	.000XX	---	1	100	Brown
Red	2	2	X,X00	.00XX	---	2	200	Red
Orange	3	3	XX,000	.0XX	±30%	3	300	Orange
Yellow	4	4	XX0,000	.XX	±40%	4	400	Yellow
Green	5	5	X,X00,000	X.X	±5%	5	500	Green
Blue	6	6	---	---	---	6	600	Blue
Violet	7	7	---	---	---	7	700	Violet
Grey	8	8	---	---	---	8	800	Grey
White	9	9	---	---	±10%	9	900	White

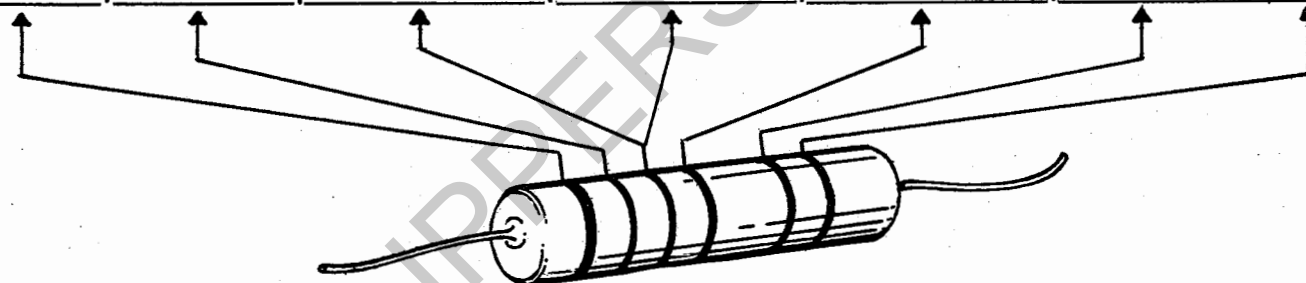

Note: Capacitors rated less than 1000 volts have only 5 bands

Example No. 1: A capacitor has 5 color bands; Brown, Black, Yellow, Black, Blue, No Band  
 This means: — — — — — 1 0 000 MMFD ±20% 6 00  
 or: — — — — — .IMFD ±20% 600 Volts

Example No. 2: A capacitor has 6 color bands; Yellow, Violet, Orange, White, Brown, Green  
 This means: — — — — — 4 7 000 MMFD ±10% 1 500  
 or: — — — — — .047 MFD ±10% 1,500 Volts

**AUTOMATIC MUSIC, INC.**

1500 UNION AVENUE, S. E., GRAND RAPIDS 2, MICHIGAN • TELEPHONE CHERRY 3-3633

**AMI**

# SERVICE BULLETIN

**AUTOMATIC MUSIC, INC.**

1500 UNION AVENUE. S. E., GRAND RAPIDS 2, MICHIGAN • TELEPHONE CHERRY 3-3633

# AMI

January 21, 1960

BULLETIN NO. 178

Model "K"

SUBJECT: Color Code for Molded Tubular Capacitors

One of our major suppliers of capacitors, Sprague Products Company, is now furnishing molded tubular capacitors identified by colored bands instead of printed values. Other manufacturers may well follow Sprague's lead.

Because of this trend, we have prepared the enclosed chart which explains the color code used for molded tubular capacitors. This system does not apply to other types of capacitors.

APPLICATIONS ENGINEERING

CLB/hr  
Attach.

COLOR	FIRST NUMBER 1st BAND	SECOND NUMBER 2nd BAND	MULTIPLIER 3rd BAND		TOLERANCE 4th BAND	VOLTAGE RATING		COLOR
			(MMFD)	(MFD)		5th BAND	6th BAND	
No Band	—	—	---	---	---	—	00	No Band
Black	—	0	---	---	±20%	—	—	Black
Brown	1	1	XX0	.000XX	---	1	100	Brown
Red	2	2	X,X00	.00XX	---	2	200	Red
Orange	3	3	XX,000	.0XX	±30%	3	300	Orange
Yellow	4	4	XX0,000	.XX	±40%	4	400	Yellow
Green	5	5	X,X00,000	X.X	±5%	5	500	Green
Blue	6	6	---	---	---	6	600	Blue
Violet	7	7	---	---	---	7	700	Violet
Grey	8	8	---	---	---	8	800	Grey
White	9	9	---	---	±10%	9	900	White

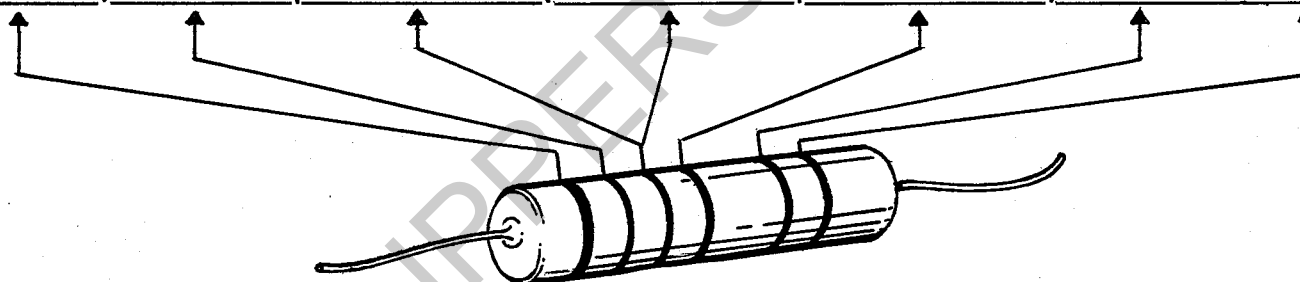

Note: Capacitors rated less than 1000 volts have only 5 bands

Example No. 1: A capacitor has 5 color bands; Brown, Black, Yellow, Black, Blue, No Band  
 This means: — — — — — 1 0 000 MMFD ±20% 6 00  
 or: — — — — — .1MFD ±20% 600 Volts

Example No. 2: A capacitor has 6 color bands; Yellow, Violet, Orange, White, Brown, Green  
 This means: — — — — — 4 7 000 MMFD ±10% 1 500  
 or: — — — — — .047 MFD ±10% 1,500 Volts

**AUTOMATIC MUSIC, INC.**

1500 UNION AVENUE. S. E. GRAND RAPIDS 2, MICHIGAN • TELEPHONE CHERRY 3-3633

**AMi**



# SERVICE BULLETIN

## AUTOMATIC MUSIC, INC.

1500 UNION AVENUE, S. E., GRAND RAPIDS 2, MICHIGAN • TELEPHONE CHERRY 3-3633

# AMI

January 21, 1960

BULLETIN NO. 179

Model "K"

SUBJECT: Beryllium Copper Wiper Blades for Pulse Converters

The wiper blades in the pulse converter are now being made from beryllium copper instead of Elkonium.

This change in material produces a stronger longer-wearing blade.

Part numbers for the new blades are:

Letter Stepper Wiper Blade	)	
Number Stepper Wiper Blade	)	
Small Blade on Letter Search Wiper Arm	)	F-8925
Number Search Wiper Blade	)	

Large Blade on Letter Search Wiper Arm      F-3498

The F-3499 Elkonium blade will be continued for use in wall box credit units and as a replacement part for Model G, H, I, and J credit units.

Beryllium copper blades should not be used in credit units previous to the Model "K" because their higher spring force will make adjustment difficult.

Be sure to order replacement blades by part number.

APPLICATIONS ENGINEERING

CLB/hr

# SERVICE BULLETIN

**AUTOMATIC MUSIC, INC.**

1500 UNION AVENUE, S. E., GRAND RAPIDS 2, MICHIGAN • TELEPHONE CHERRY 3-3633

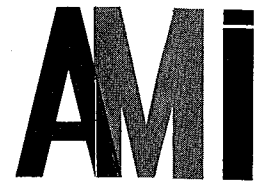

January 21, 1960

BULLETIN NO. 179

Model "K"

SUBJECT: Beryllium Copper Wiper Blades for Pulse Converters

The wiper blades in the pulse converter are now being made from beryllium copper instead of Elkonium.

This change in material produces a stronger longer-wearing blade.

Part numbers for the new blades are:

Letter Stepper Wiper Blade	)	
Number Stepper Wiper Blade	)	
Small Blade on Letter Search Wiper Arm	)	F-8925
Number Search Wiper Blade	)	

Large Blade on Letter Search Wiper Arm	F-3498
--	--------

The F-3499 Elkonium blade will be continued for use in wall box credit units and as a replacement part for Model G, H, I, and J credit units.

Beryllium copper blades should not be used in credit units previous to the Model "K" because their higher spring force will make adjustment difficult.

Be sure to order replacement blades by part number.

APPLICATIONS ENGINEERING

CLB/hr

# SERVICE BULLETIN

**AUTOMATIC MUSIC, INC.**

1500 UNION AVENUE, S. E., GRAND RAPIDS 2, MICHIGAN • TELEPHONE CHERRY 3-3633

# AMI

January 21, 1960

BULLETIN NO. 180

Model "K"

SUBJECT: H-3333-H Speaker Control

This bulletin announces the H-3333-H Speaker Control. This is a remote volume control for individual remote speakers.

It is intended for use where it is desirable to control one speaker independently of any others in the system.

The control is housed in an attractive case that can be mounted on a wall or under a bar. A fifty foot cable is supplied.

While the H-3333-H is designed as an accessory for AMI cylindrical speakers, it will work with any speaker having an 8 ohm voice coil.

The attached sheet shows how the control may be connected to various types of speakers.

APPLICATIONS ENGINEERING

CLB/hr  
Attach.

Page 1 of 2

SINCE 1909 DESIGNERS, ENGINEERS AND MANUFACTURERS OF AUTOMATIC MUSICAL INSTRUMENTS FOR BUSINESS AND INDUSTRY

AFFILIATE OF *AUTOMATIC*  
CANTEN COMPANY OF AMERICA

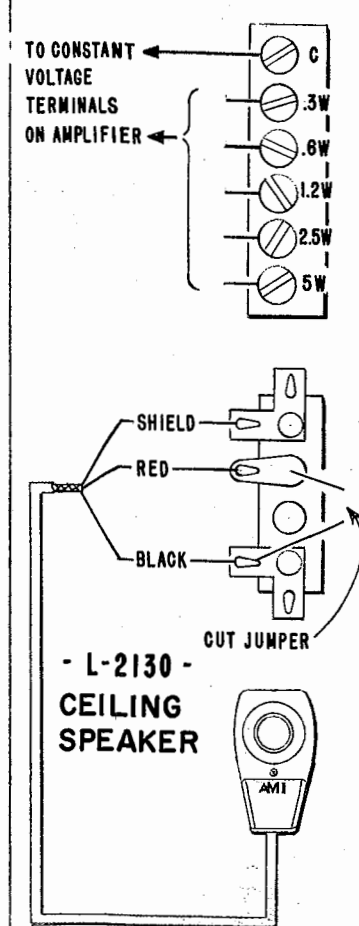
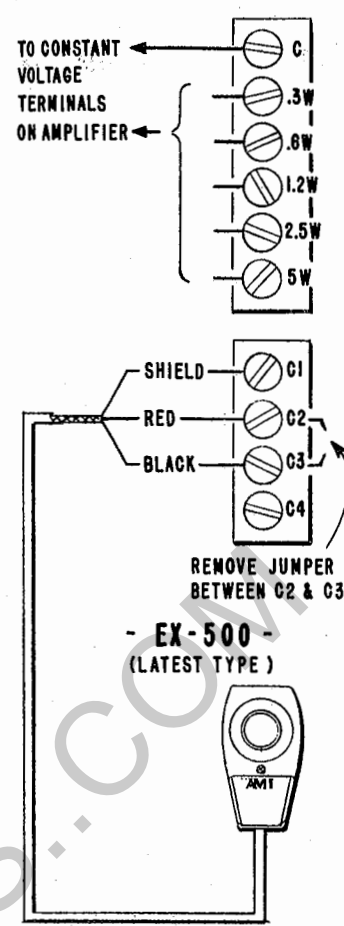
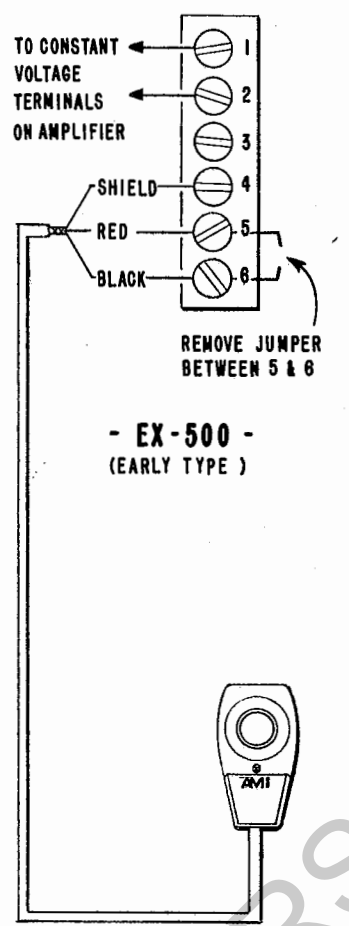
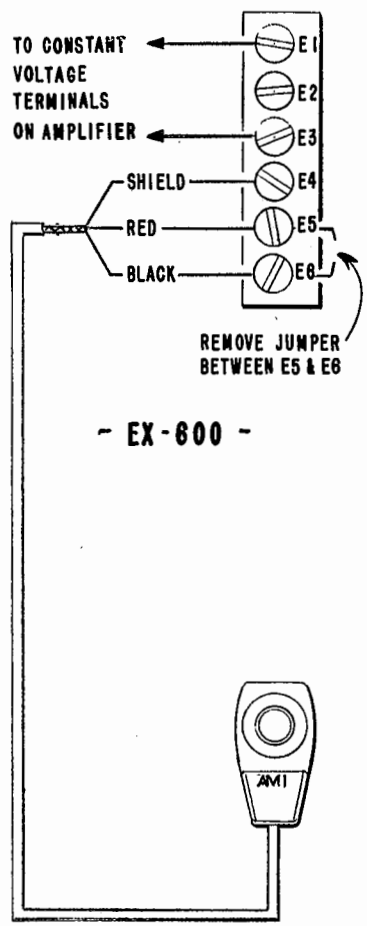

When constant voltage speakers are used, set the wattage of each speaker at the highest level that will ever be required in the area the speaker serves. Make sure, however, that the total wattage of *all* speakers connected to a single amplifier does not exceed 20. The wattage setting and the setting of the main volume control will determine the *maximum* loudness of each speaker. The speaker control is used to adjust the loudness of individual speakers as conditions vary.

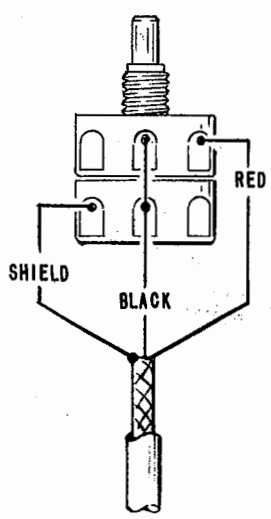

H-3333-H  
SPEAKER CONTROL  
(INTERNAL CONNECTIONS)

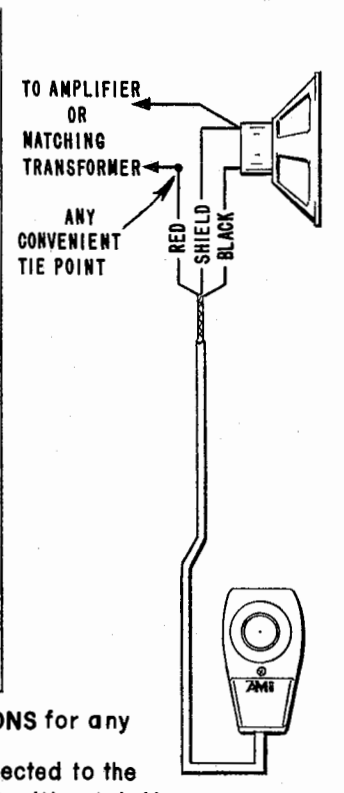

**GENERAL CONNECTIONS** for any eight ohm speaker.  
The lines must be connected to the amplifier at *taps that will not deliver more than 10 watts* to the speaker.

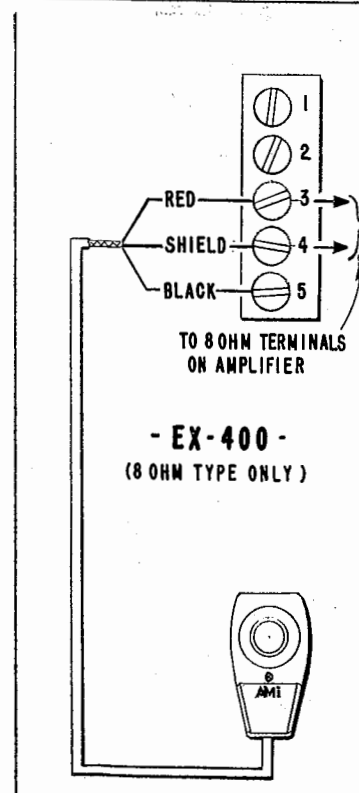

# SERVICE BULLETIN

**AUTOMATIC MUSIC, INC.**

1500 UNION AVENUE, S. E., GRAND RAPIDS 2, MICHIGAN • TELEPHONE CHERRY 3-3633

# AMI

January 21, 1960

BULLETIN NO. 180

Model "K"

SUBJECT: H-3333-H Speaker Control

This bulletin announces the H-3333-H Speaker Control. This is a remote volume control for individual remote speakers.

It is intended for use where it is desirable to control one speaker independently of any others in the system.

The control is housed in an attractive case that can be mounted on a wall or under a bar. A fifty foot cable is supplied.

While the H-3333-H is designed as an accessory for AMI cylindrical speakers, it will work with any speaker having an 8 ohm voice coil.

The attached sheet shows how the control may be connected to various types of speakers.

APPLICATIONS ENGINEERING

CLB/hr  
Attach.

Page 1 of 2

SINCE 1909 DESIGNERS, ENGINEERS AND MANUFACTURERS OF AUTOMATIC MUSICAL INSTRUMENTS FOR BUSINESS AND INDUSTRY

AFFILIATE OF *AUTOMATIC*  
CANTEN COMPANY OF AMERICA

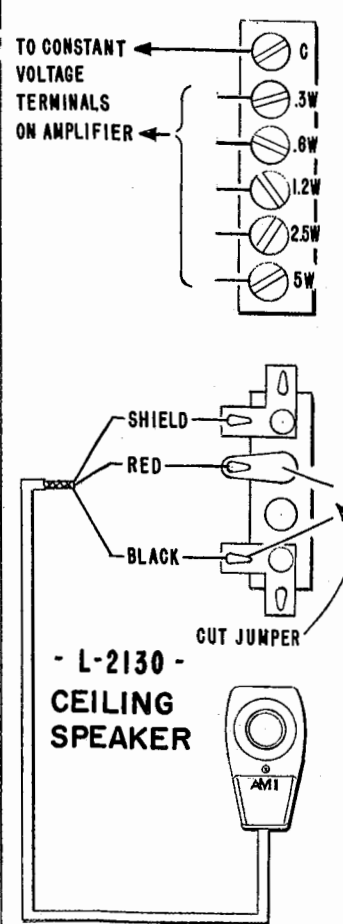
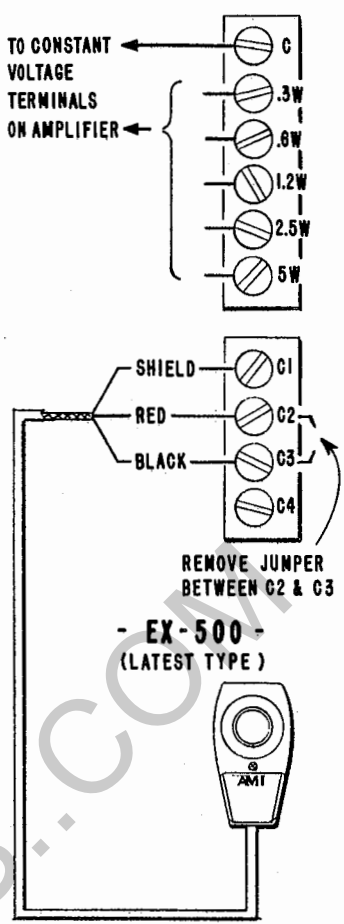
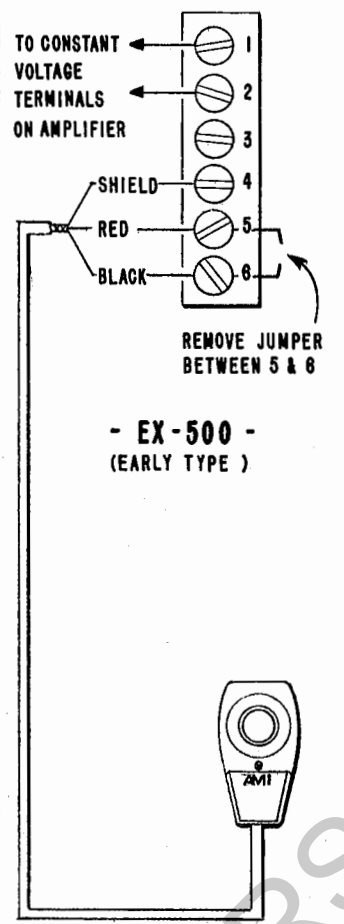
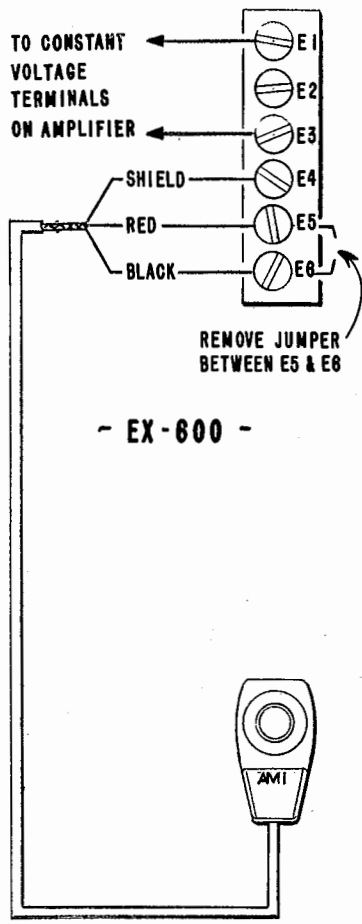

When constant voltage speakers are used, set the wattage of each speaker at the highest level that will ever be required in the area the speaker serves. Make sure, however, that the total wattage of *all* speakers connected to a single amplifier does not exceed 20. The wattage setting and the setting of the main volume control will determine the *maximum* loudness of each speaker. The speaker control is used to adjust the loudness of individual speakers as conditions vary.

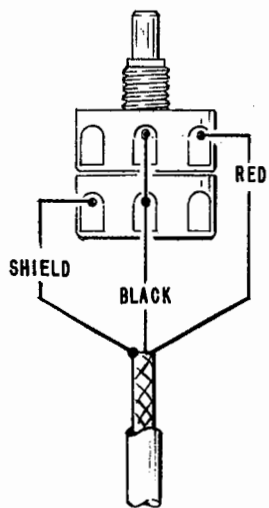

H-3333-H  
 SPEAKER CONTROL  
 (INTERNAL CONNECTIONS)

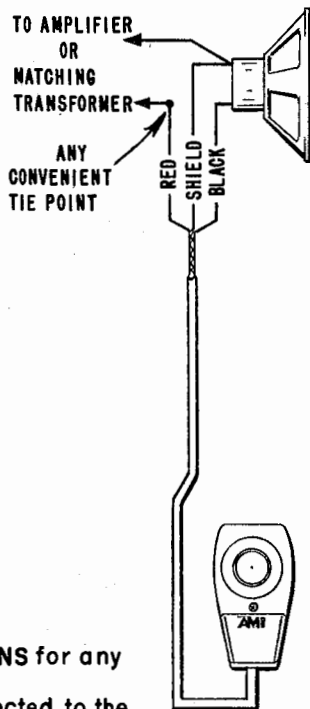

GENERAL CONNECTIONS for any eight ohm speaker.  
 The lines must be connected to the amplifier at *taps that will not deliver more than 10 watts* to the speaker.

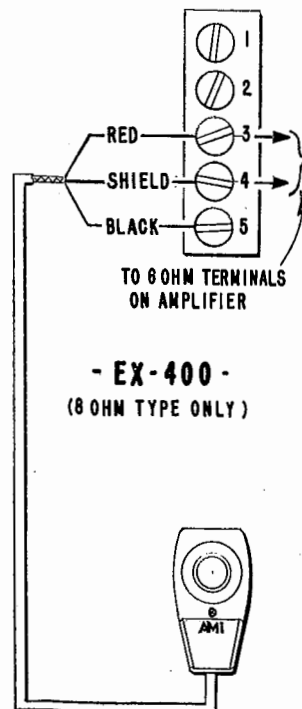

# SERVICE BULLETIN

## AUTOMATIC MUSIC, INC.

1500 UNION AVENUE, S. E., GRAND RAPIDS 2, MICHIGAN • TELEPHONE CHERRY 3-3633

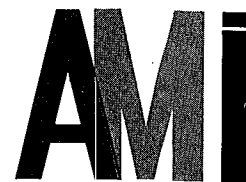

February 29, 1960

BULLETIN NO. 181

Model "K"

SUBJECT: Instruction Chart for F-7830 Credit Circuit Board, Plug & Bracket Assembly

When shipped from the factory, all phonographs are set for certain price-of-play combinations which are the most widely used combinations in this country. However, in many cases, these price-of-play combinations are changed to suit local conditions and one primary area in the phonograph where these changes are made is in the location of the small nickel-plated screws in the credit circuit board.

The attached chart has been prepared to help acquaint you with the exact purpose of each portion of this credit circuit board. Each screw in this credit circuit board acts as a switch which, when inserted, serves to connect a portion of a circuit on the front of the board to another portion on the back side of the board.

We believe the chart will be of value to you in understanding exactly what can be accomplished by inserting the screws in the various combinations of holes which are available.

APPLICATIONS ENGINEERING

KHH/hr  
Attach.

A screw in hole #3 causes the adjustable electrical credit stop to be energized by the ten cent coin switch.

A screw in hole #4 causes the adjustable electrical credit stop coil to be energized by the twenty-five cent coin switch.

A screw in hole #5 causes the TWENTY-FIVE CENT COIN SWITCH to energize the main credit solenoid without energizing any electrical stop.

A screw in hole #6 causes the FIFTY CENT COIN SWITCH to energize the main credit solenoid without energizing any electrical stop.

PLUG CLIPS  
ON THIS SIDE

SLUG  
REJECTOR  
25¢ 50¢

Screw should be placed in hole #7 when a price-of-play is used which does not require the use of the PH-26 Fifty Cent Unit.

Screw should be placed in hole #8 when a price-of-play is used which requires a PH-26 Fifty Cent Unit.

A screw in hole #1 causes the fixed "one step" electrical credit stop to be energized by the five cent coin switch.

A screw in hole #2 causes the "one step" electrical stop to be energized by the ten cent coin switch.

A screw in hole #9 causes the five cent credit light to be turned on when the credit wheel moves one step from home position.

A screw in hole #10 causes the ten cent credit light to be turned on when the credit wheel moves one step from home position.

A screw in hole #11 causes the ten cent light to go on when the credit unit moves two steps from home position.

A screw in hole #12 causes the "15¢ or more" light to go on when the credit unit moves two steps from home position.

A screw in hole #15 connects the "two step" credit ring as the E.P. credit switch. (This makes it possible to make an E.P. selection when the credit unit is two steps from home position.)

A screw in hole #16 connects the "three step" credit ring as the E.P. credit switch. (This makes it necessary for the credit unit to move three steps from home position before an E.P. selection can be made.)

PRICE PER STEP  
(CREDIT WHEEL)

DUAL PRICE PLAY

5¢ 10¢ 5¢ 10¢

5¢ 10¢ 5¢ 10¢  
10¢ 15¢ 10¢ 15¢

When a single price combination (not dual pricing) is used:

- When giving one play for one credit tooth, screws must be placed in holes #13, 14 and 15 (no screw in hole #16).
- When giving one play for two credit teeth, screws must be placed in holes #14, 15 and 16 (no screw in hole #13).

A screw in hole #13 connects the "one step" credit ring as the "standard" credit switch. (This makes it possible to make a "standard priced" selection with the credit wheel one step from home position.

A screw in hole #14 connects the "two step" credit ring as the "standard" credit switch. (This makes it necessary for the credit unit to be two steps from home position before a "standard priced" selection can be made.

**AUTOMATIC MUSIC, INC.**

1500 UNION AVENUE, S. E., GRAND RAPIDS 2, MICHIGAN • TELEPHONE CHERRY 3-3633

**AMI**



# SERVICE BULLETIN

## AUTOMATIC MUSIC, INC.

1500 UNION AVENUE, S. E., GRAND RAPIDS 2, MICHIGAN • TELEPHONE CHERRY 3-3633

# AMI

February 29, 1960

BULLETIN NO. 181

Model "K"

SUBJECT: Instruction Chart for F-7830 Credit Circuit  
Board, Plug & Bracket Assembly

When shipped from the factory, all phonographs are set for certain price-of-play combinations which are the most widely used combinations in this country. However, in many cases, these price-of-play combinations are changed to suit local conditions and one primary area in the phonograph where these changes are made is in the location of the small nickel-plated screws in the credit circuit board.

The attached chart has been prepared to help acquaint you with the exact purpose of each portion of this credit circuit board. Each screw in this credit circuit board acts as a switch which, when inserted, serves to connect a portion of a circuit on the front of the board to another portion on the back side of the board.

We believe the chart will be of value to you in understanding exactly what can be accomplished by inserting the screws in the various combinations of holes which are available.

APPLICATIONS ENGINEERING

KHH/hr  
Attach.

A screw in hole #3 causes the adjustable electrical credit stop to be energized by the ten cent coin switch.

A screw in hole #4 causes the adjustable electrical credit stop coil to be energized by the twenty-five cent coin switch.

A screw in hole #5 causes the TWENTY-FIVE CENT COIN SWITCH to energize the main credit solenoid without energizing any electrical stop.

A screw in hole #6 causes the FIFTY CENT COIN SWITCH to energize the main credit solenoid without energizing any electrical stop.

PLUG CLIPS  
ON THIS SIDE

SLUG  
REJECTOR  
25¢ 50¢

Screw should be placed in hole #7 when a price-of-play is used which does not require the use of the PH-26 Fifty Cent Unit.

Screw should be placed in hole #8 when a price-of-play is used which requires a PH-26 Fifty Cent Unit.

A screw in hole #1 causes the fixed "one step" electrical credit stop to be energized by the five cent coin switch.

A screw in hole #2 causes the "one step" electrical stop to be energized by the ten cent coin switch.

A screw in hole #9 causes the five cent credit light to be turned on when the credit wheel moves one step from home position.

A screw in hole #10 causes the ten cent credit light to be turned on when the credit wheel moves one step from home position.

A screw in hole #11 causes the ten cent light to go on when the credit unit moves two steps from home position.

A screw in hole #12 causes the "15¢ or more" light to go on when the credit unit moves two steps from home position.

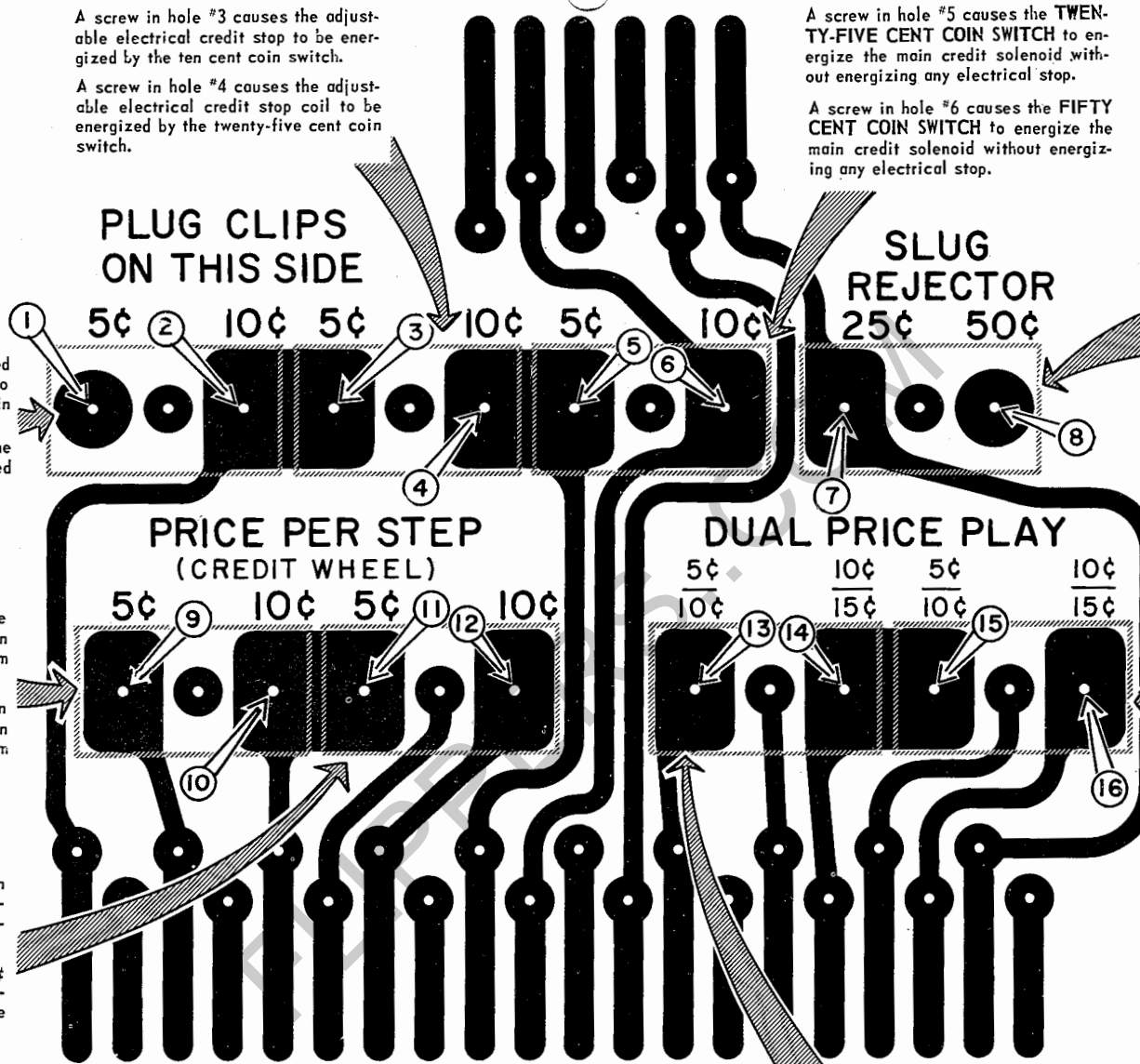

When a single price combination (not dual pricing) is used:

- (a) When giving one play for one credit tooth, screws must be placed in holes #13, 14 and 15 (no screw in hole #16).
- (b) When giving one play for two credit teeth, screws must be placed in holes #14, 15 and 16 (no screw in hole #13).

A screw in hole #13 connects the "one step" credit ring as the "standard" credit switch. (This makes it possible to make a "standard priced" selection with the credit wheel one step from home position.)

A screw in hole #14 connects the "two step" credit ring as the "standard" credit switch. (This makes it necessary for the credit unit to be two steps from home position before a "standard priced" selection can be made.)

A screw in hole #15 connects the "two step" credit ring as the E.P. credit switch. (This makes it possible to make an E.P. selection when the credit unit is two steps from home position.)

A screw in hole #16 connects the "three step" credit ring as the E.P. credit switch. (This makes it necessary for the credit unit to move three steps from home position before an E.P. selection can be made.)

**AUTOMATIC MUSIC, INC.**

1500 UNION AVENUE, S. E., GRAND RAPIDS 2, MICHIGAN • TELEPHONE CHERRY 3-3633

**AMi**

# AUTOMATIC MUSIC, INC.

1500 UNION AVENUE, S. E., GRAND RAPIDS 2, MICHIGAN • TELEPHONE CHERRY 3-3633

# AMI

March 16, 1960

St. Thomas Coin Sales  
79-1/2 Maitland St.  
London, Ontario, Canada

Gentlemen:

This AMI Service Information Binder has been designed for your convenience. It has a serial number stamped inside the back cover and is registered in your name. As new manuals are printed, they will be forwarded to you for insertion into your Binder. All you need to do is to insert the new information in the appropriate section as indicated.

You will notice that space is provided for all AMI Service Information, thus providing you with a convenient, single source.

An index is included in the front. You will notice that the Service Information is complete to date, beginning with the Model "K" Phonograph. As new sections are sent to you, a revised replacement index will be included. In this way, your Service Information will be kept up-to-the-minute.

This volume is marked "Book I-A." When it is filled, a third Binder will be issued.

Additional Binders may be obtained by writing to the Technical Publications Department.

APPLICATIONS ENGINEERING  
TECHNICAL PUBLICATIONS  
DEPARTMENT

WHK/hr

SINCE 1909 DESIGNERS, ENGINEERS AND MANUFACTURERS OF AUTOMATIC MUSICAL INSTRUMENTS FOR BUSINESS AND INDUSTRY

AFFILIATE OF *AUTOMATIC*  
CANTEN COMPANY OF AMERICA

# SERVICE BULLETIN

## AUTOMATIC MUSIC, INC.

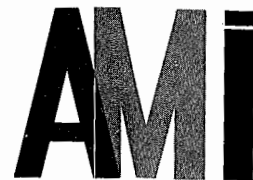

1500 UNION AVENUE, S. E., GRAND RAPIDS 2, MICHIGAN • TELEPHONE CHERRY 3-3633

June 17, 1960

BULLETIN NO. 182  
Model "K"

SUBJECT: R-2017-A and R-2017-B Basic Amplifiers

The basic amplifier used in standard Model "K" Phonographs can not be used as direct replacements in Continental and Lyric Phonographs.

Since the amplifiers are mounted with the 5U4 tubes horizontal, the sockets must be positioned so that the tubes' filaments will not sag against the plates.

In the standard Model "K", the keyway in the 5U4 socket must point toward the end of the chassis. In the Continental and Lyric, the keyway must point toward the power transformer.

Amplifiers intended for use in the standard Model "K" are marked R-2017 or R-2017-A. Amplifiers intended for use in the Continental or Lyric are marked R-2017-B.

The stereo preamplifiers, add-on power amplifiers, and monaural pre-amplifiers can be used interchangeably in all machines.

APPLICATIONS ENGINEERING

CLB/hr

# SERVICE BULLETIN

## AUTOMATIC MUSIC, INC.

1500 UNION AVENUE, S. E., GRAND RAPIDS 2, MICHIGAN • TELEPHONE CHERRY 3-3633

# AMI

July 6, 1960

BULLETIN NO. 183  
Model "K"

SUBJECT: E.P. Switch Actuators

E.P. switch actuators for Continental and Lyric Phonographs are assembled and mounted differently than on standard Model "K's".

On the Continental and Lyric, the actuator must be mounted on the right-hand end (as viewed from the front of the machine) of the letter push-button bank and the switch operating tab must be on the right-hand end of the actuator.

When ordering E.P. actuators, specify part number F-7742-C for standard Model "K's" and F-7742-D for Continentals and Lyrics.

Either version of the actuators can be readily changed to the other by moving the switch operating tab and associated bracket.

APPLICATIONS ENGINEERING

CLB/hr

# SERVICE BULLETIN

AUTOMATIC MUSIC, INC.

1500 UNION AVENUE, S. E., GRAND RAPIDS 2, MICHIGAN • TELEPHONE CHERRY 3-3633

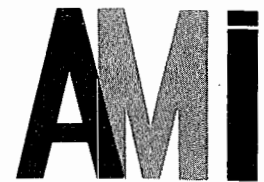

July 6, 1960

BULLETIN NO. 184

SUBJECT: Steppers for the Continental & Lyric

A line of steppers is available for using wallboxes with Continental and Lyric Automatic Phonographs.

These steppers are in two sections - one containing the relays and the other the stepping switches. When mounted in the phonograph, the relay package will fit to the right of the automatic search unit and the stepping switches will fit underneath the popularity meter. Clips and thumbscrew holes are provided in the mechanism shelf of the phonograph for easy mounting of the units.

Four types of steppers are available:

- Model CCA - to be installed on Continentals to accommodate AMI Wallboxes.
- Model CCB - to be installed on Lyrics to accommodate AMI Wallboxes.
- Model CCC - to be installed on Continentals to accommodate competitive wallboxes.
- Model CCD - to be installed on Lyrics to accommodate Seeburg 100-Selection Wallboxes.

These steppers will work equally well on standard Model K's. Therefore, when the present supply of single unit steppers (CBA, CBB, CBC, & CBD) is exhausted, only the two section steppers will be available.

APPLICATIONS ENGINEERING

CLB/hr

SINCE 1909 DESIGNERS, ENGINEERS AND MANUFACTURERS OF AUTOMATIC MUSICAL INSTRUMENTS FOR BUSINESS AND INDUSTRY

AFFILIATE OF *AUTOMATIC*  
CANTEEN COMPANY OF AMERICA

# SERVICE BULLETIN

AUTOMATIC MUSIC, INC.

1500 UNION AVENUE. S. E., GRAND RAPIDS 2, MICHIGAN • TELEPHONE CHERRY 3-3633

# AMi

July 6, 1960

BULLETIN NO. 185  
Model "K"

SUBJECT: Mounting of CCA, CCB, CCC, & CCD Steppers

When any of subject steppers are mounted in the phonograph, they must be allowed to "float" on the rubber grommets in their mounting brackets.

If the thumbscrews which hold down the front brackets are tightened too much, the frame of the unit will be warped and cause the number stepper to fail.

Make sure these screws are not tightened enough to compress the rubber grommets in the front mounting brackets.

APPLICATIONS ENGINEERING

CLB/hr

# SERVICE BULLETIN

AUTOMATIC MUSIC, INC.

1500 UNION AVENUE, S. E., GRAND RAPIDS 2, MICHIGAN • TELEPHONE CHERRY 3-3633

# AMI

August 18, 1960

BULLETIN NO. 186

## Model K, Lyric, Continental

SUBJECT: Tone Arm and Bias Spring Adjustments

Since the publication of the Model K Record Changer Service Manual, certain changes have been made to the tone arm that make it easier to obtain proper tone tracking at low needle pressure. These changes are:

The addition of a counterbalance weight to the tone arm,  
The addition of a stiffener blade to the needle pressure adjustment spring,  
New, light-weight tone arm cable,  
A new "safety pin" type tone arm bias spring.

The adjustments of the tone arm bias spring are shown in the attached illustration. When the adjustments are correct, there will be a very small outward force on the tone arm when the needle sets down and also at the cutoff point.

To check the lateral force on the tone arm, prop it up by inserting a match, paper clip, or the like, between the tone arm and its rest. The tone arm should not swing in. It should have a tendency to drift out. The force required to push the tone arm in to the point where the cutoff switch operates should not be more than 1-1/2 grams. This should be measured level with the needle.

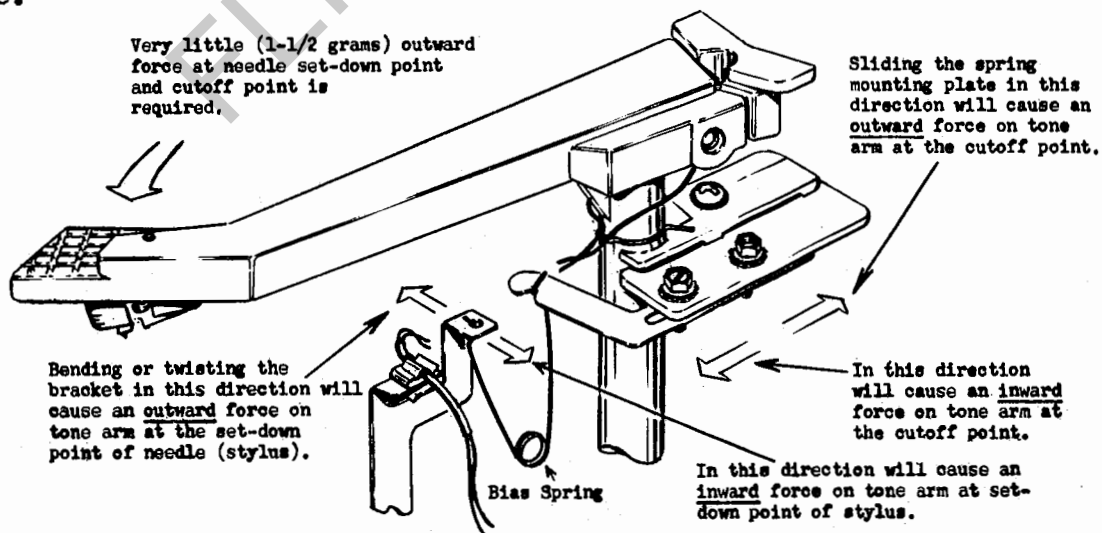

CLB/hr

APPLICATIONS ENGINEERING

SINCE 1909 DESIGNERS, ENGINEERS AND MANUFACTURERS OF AUTOMATIC MUSICAL INSTRUMENTS FOR BUSINESS AND INDUSTRY

AFFILIATE OF AUTOMATIC  
CANTEN COMPANY OF AMERICA



# SERVICE BULLETIN

AUTOMATIC MUSIC, INC.

1500 UNION AVENUE, S. E., GRAND RAPIDS 2, MICHIGAN • TELEPHONE CHERRY 3-3633

# AMi

August 18, 1960

BULLETIN NO. 186

## Model K, Lyric, Continental

SUBJECT: Tone Arm and Bias Spring Adjustments

Since the publication of the Model K Record Changer Service Manual, certain changes have been made to the tone arm that make it easier to obtain proper tone tracking at low needle pressure. These changes are:

The addition of a counterbalance weight to the tone arm,  
The addition of a stiffener blade to the needle pressure adjustment spring,  
New, light-weight tone arm cable,  
A new "safety pin" type tone arm bias spring.

The adjustments of the tone arm bias spring are shown in the attached illustration. When the adjustments are correct, there will be a very small outward force on the tone arm when the needle sets down and also at the cutoff point.

To check the lateral force on the tone arm, prop it up by inserting a match, paper clip, or the like, between the tone arm and its rest. The tone arm should not swing in. It should have a tendency to drift out. The force required to push the tone arm in to the point where the cutoff switch operates should not be more than 1-1/2 grams. This should be measured level with the needle.

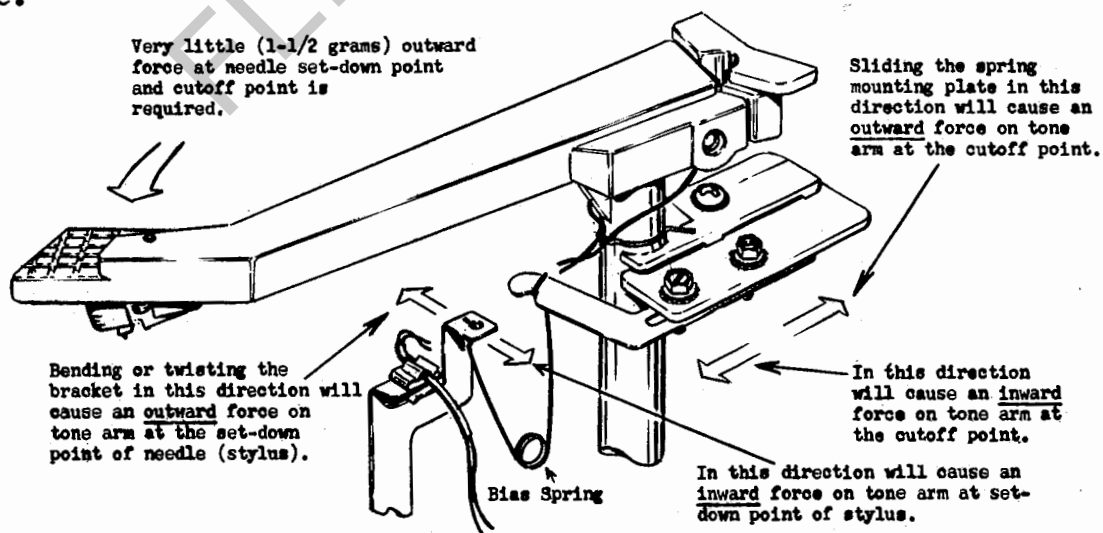

CLB/hr

APPLICATIONS ENGINEERING

SINCE 1909 DESIGNERS, ENGINEERS AND MANUFACTURERS OF AUTOMATIC MUSICAL INSTRUMENTS FOR BUSINESS AND INDUSTRY

AFFILIATE OF *AUTOMATIC*  
CANTEN COMPANY OF AMERICA

# SERVICE BULLETIN

**AUTOMATIC MUSIC, INC.**

# AMi

1500 UNION AVENUE, S. E., GRAND RAPIDS 2, MICHIGAN • TELEPHONE CHERRY 3-3633

October 7, 1960

**BULLETIN #187**

**Continental/Lyric**

**SUBJECT: Changes in the Automatic Selector and Automatic Search Unit**

During recent weeks we have made some changes in the automatic selector and the automatic search unit of the "Lyric" and "Continental" 100 and 200 Automatic Phonographs which will affect interchangeability of components.

The primary purpose of making this change has been to improve the pushbutton unlatching function. Previously the unlatching function occurred almost simultaneously with the sprag, select, cancel and scan functions in the phonograph. This simultaneous power drain has a tendency to reduce the available power to each individual coil. In the new circuit the unlatching solenoid is energized after the sprag, select, scan and cancel functions have been completed thus availing full power of the power supply to the unlatched solenoid.

Concurrent with this change has been a change in the coupling arrangement between the automatic search unit bullet and the pin pusher tube. This change was made to facilitate the adjustment of pin pusher to pin alignment. The change involved here is merely a reversal of the male to female fit of the bullet to the tube.

Because of the circuit changes, the new components are not interchangeable with older components now in the field.

The new automatic selector unit can be identified by the gold color (dichromate finish) of its mounting plate. The old automatic selector assembly can be identified by the silver colored (cadmium-plated finish) mounting plate. The new automatic search unit can be identified by the shape of the bullet. The new automatic search unit has a blunt bullet with a hole in the end. The old automatic search unit has a pin protruding from the end of the bullet.

- 1 -

The coupling to the pin pusher of the manual selector unit has been similarly changed.

Identification of phonographs with these changes thru serial numbers can be determined as follows:

<u>Model</u>	<u>Serial No.</u>
100 Selection Automatic	615611
100 Selection Automatic (Stereo)	620101
100 Selection Manual	605111
200 Selection Automatic	595881
200 Selection Automatic (Stereo)	600501
200 Selection Manual	585031

If the occasion arises where early versions of the R-1893 (CCA, CCB, CCC and CCD) stepper are used with the new version of phonographs, it will be necessary to insert a jumper wire into the wiring harness of the stepper unit. This jumper wire must be inserted from pin #9 of the 9-connection female plug which connects to the receiver to pin #9 of the 9-connection male plug which connects to the transmitter. These plugs can be identified by the fact that they also contain yellow, black, black/white and red/white wires. No other plugs in the stepper unit contain this same combination of colors. Late models of the R-1893 steppers will already contain this jumper wire as supplied from the factory.

Because interchangeability has been affected, new assembly numbers have been assigned for the automatic selector unit and automatic search units. These new and old assembly numbers are as follows:

	<u>New Assembly Number</u>	<u>Old Assembly Number</u>
<u>Automatic Selector Unit</u>		
200 Automatic	R-1865-E	R-1865-A
100 Automatic	R-1865-F	R-1865-B
<u>Automatic Search Unit</u>		
200 Automatic	R-2405-F	R-2405-C
100 Automatic	R-2405-G	R-2405-D

# SERVICE BULLETIN

## AUTOMATIC MUSIC, INC.

1500 UNION AVENUE, S. E., GRAND RAPIDS 2, MICHIGAN • TELEPHONE CHERRY 3-3633

# AMi

**BULLETIN No. 188**

### **NEW CIRCUIT BOARD AND FUSE FOR THE R-1473 CREDIT UNIT**

Hi! In case we have not met before, my name is SWAMI — in recognition of my years of "Service With AMI." I am devoted to helping operators and service men enjoy trouble-free and profitable performance of their AMI equipment.

In offering the new circuit board and fuse feature, as announced in this bulletin, we are following the AMI tradition of offering you another opportunity to keep your present equipment up-to-date and trouble free.

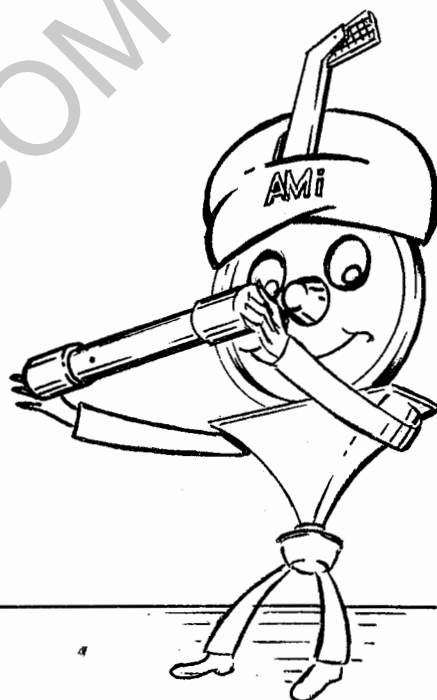

A recent change in the R-1473 credit unit incorporates an 8/10 amp. slow blow fuse on the switch circuit assembly. This fuse protects the main credit solenoid in case a light weight or bent coin lodges on the coin switches.

This change requires a new switch circuit board assembly (part No. F-10344) which replaces and supersedes earlier versions of this part.

The new switch circuit board can be used in all versions of the R-1473 credit unit. The following sketches show the proper connections.

**See illustrations on second page of this bulletin**

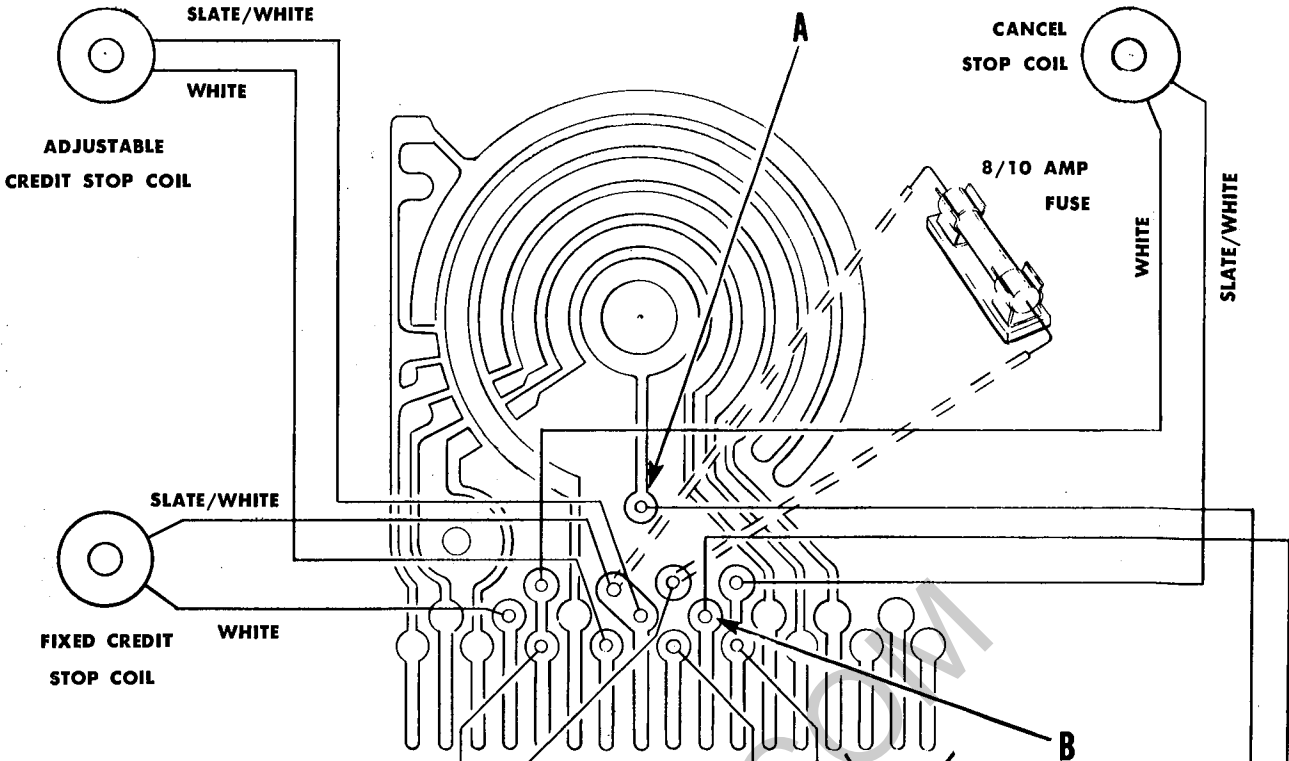

NOTE: FOR CREDIT UNITS THAT DO NOT HAVE A PLUNGER SWITCH, JUMPER POINTS A AND B

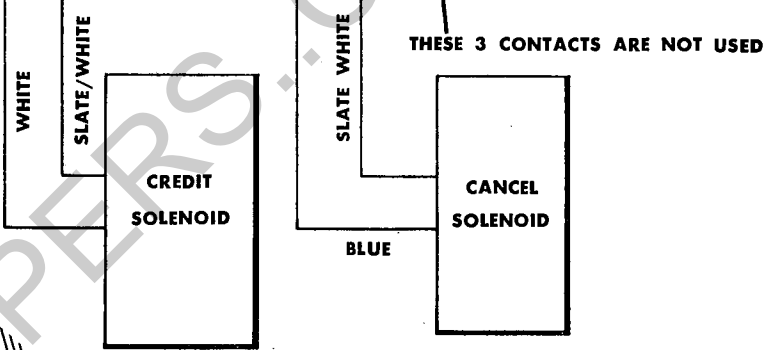

F-10344 SWITCH CIRCUIT ASSEMBLY

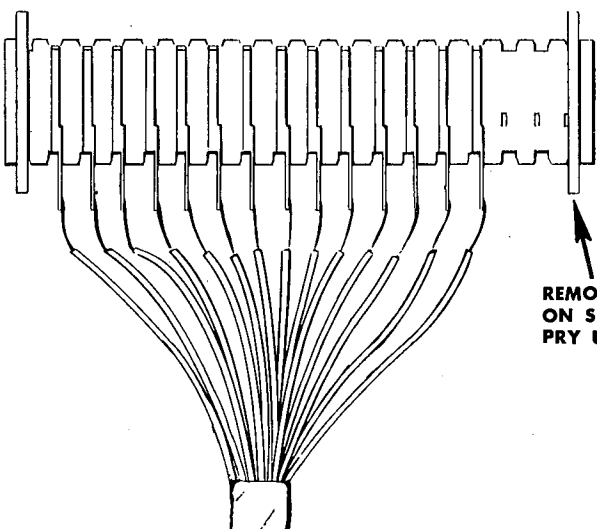
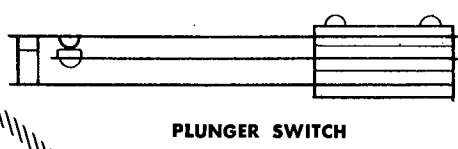
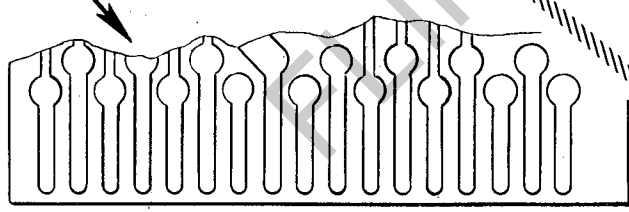

REMOVE THIS GUIDE ON SHORT EDGE CONNECTORS  
PRY UP CLIPS TO REMOVE

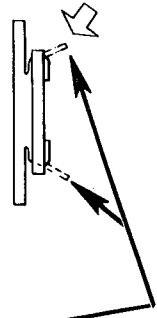

# SERVICE BULLETIN

## AUTOMATIC MUSIC, INC.

1500 UNION AVENUE, S. E., GRAND RAPIDS 2, MICHIGAN • TELEPHONE CHERRY 3-3633

# AMi

**BULLETIN No. 188**

### **NEW CIRCUIT BOARD AND FUSE FOR THE R-1473 CREDIT UNIT**

Hi! In case we have not met before, my name is SWAMI — in recognition of my years of "Service With AMI." I am devoted to helping operators and service men enjoy trouble-free and profitable performance of their AMI equipment.

In offering the new circuit board and fuse feature, as announced in this bulletin, we are following the AMI tradition of offering you another opportunity to keep your present equipment up-to-date and trouble free.

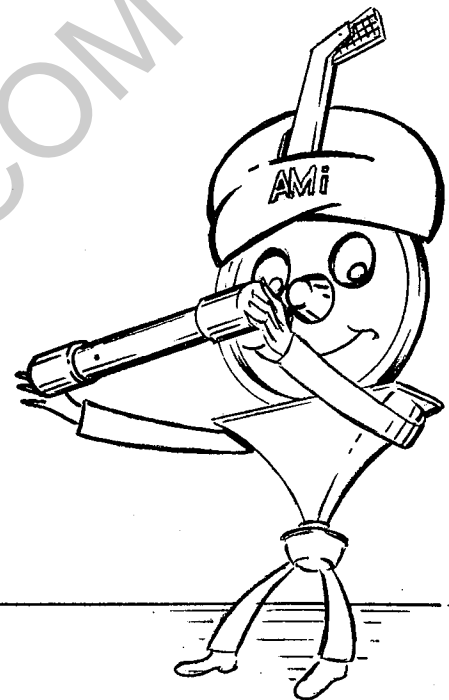

A recent change in the R-1473 credit unit incorporates an 8/10 amp. slow blow fuse on the switch circuit assembly. This fuse protects the main credit solenoid in case a light weight or bent coin lodges on the coin switches.

This change requires a new switch circuit board assembly (part No. F-10344) which replaces and supersedes earlier versions of this part.

The new switch circuit board can be used in all versions of the R-1473 credit unit. The following sketches show the proper connections.

**See illustrations on second page of this bulletin**

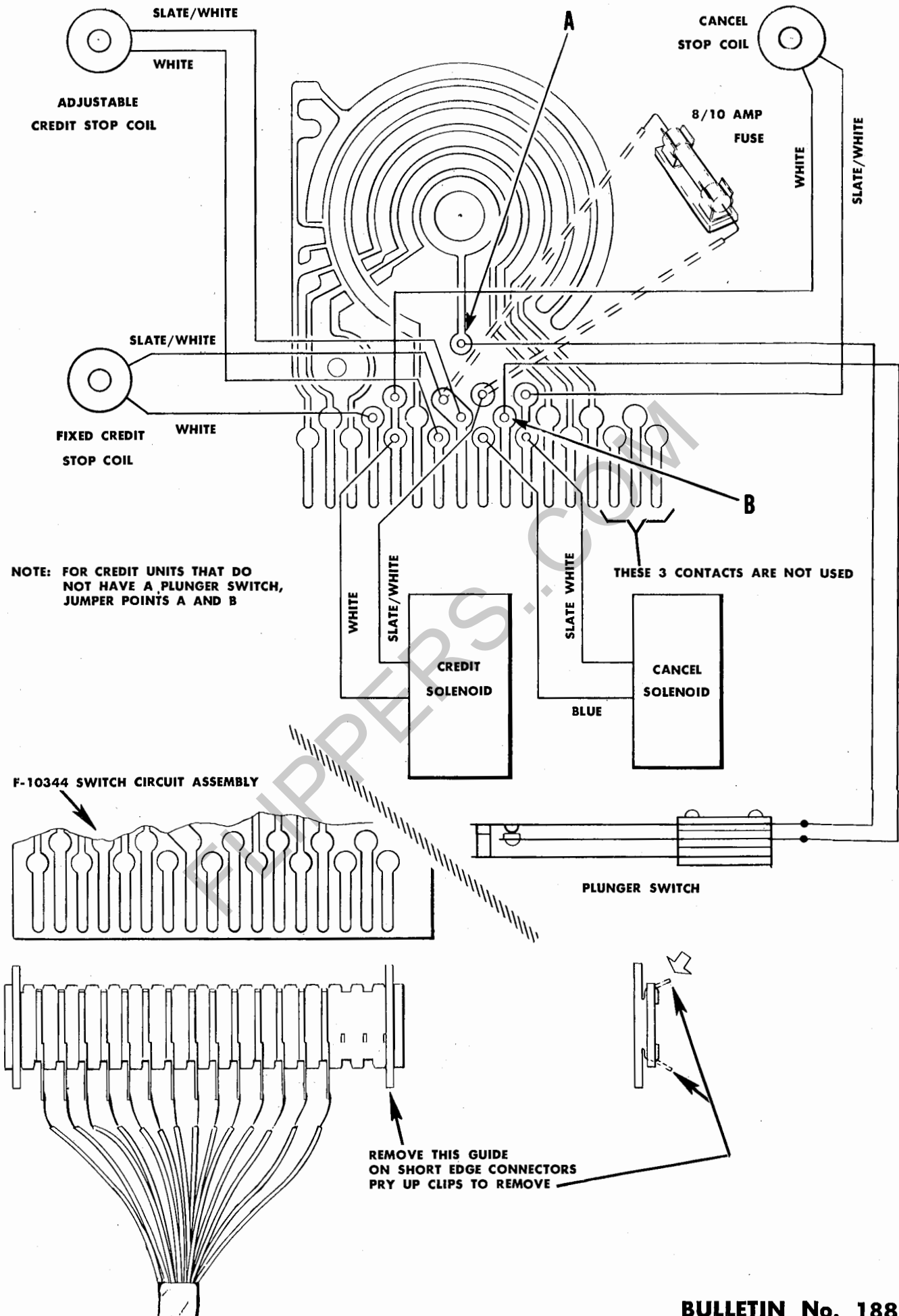

# SERVICE BULLETIN

## AUTOMATIC MUSIC, INC.

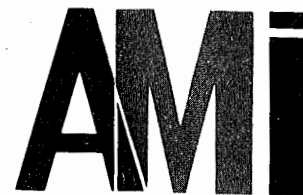

1500 UNION AVENUE, S. E., GRAND RAPIDS 2, MICHIGAN • TELEPHONE CHERRY 3-3633

May 1, 1961

### BULLETIN NO. 189

Subject: Instructions for using Stereo Cartridge with a Monaural Amplifier

1. Remove the monaural cartridge and install the stereo cartridge.
2. Unsolder the pin terminals from the tone arm cable and replace with the clip terminals packed with the stereo cartridge. The "R" terminal and the "L" terminal on the cartridge should be connected together and both connected to the red wire in the phono cable. The remaining two terminals should be connected together and connected to the black wire in the phono cable. Thus each of the two wires in the phono cable should have two clip terminals soldered to it. The shield on the stereo cartridge should not be grounded at the terminals just as the shield is not grounded at the terminals on the monaural cartridge.
3. Check stylus force after the stereo cartridge is installed to see that it is between 5 and 7 grams.
4. Check needle height and readjust if necessary.

FIELD SERVICE ENGINEERING

SINCE 1909 DESIGNERS, ENGINEERS AND MANUFACTURERS OF AUTOMATIC MUSICAL INSTRUMENTS FOR BUSINESS AND INDUSTRY

AFFILIATE OF *AUTOMATIC*  
CANTEN COMPANY OF AMERICA



# SERVICE BULLETIN

**AUTOMATIC MUSIC, INC.**

**AMi**

1500 UNION AVENUE, S. E., GRAND RAPIDS 2, MICHIGAN • TELEPHONE CHERRY 3-3633

May 1, 1961

BULLETIN NO. 189

Subject: Instructions for using Stereo Cartridge with a  
Monaural Amplifier

1. Remove the monaural cartridge and install the stereo cartridge.
2. Unsolder the pin terminals from the tone arm cable and replace with the clip terminals packed with the stereo cartridge. The "R" terminal and the "L" terminal on the cartridge should be connected together and both connected to the red wire in the phono cable. The remaining two terminals should be connected together and connected to the black wire in the phono cable. Thus each of the two wires in the phono cable should have two clip terminals soldered to it. The shield on the stereo cartridge should not be grounded at the terminals just as the shield is not grounded at the terminals on the monaural cartridge.
3. Check stylus force after the stereo cartridge is installed to see that it is between 5 and 7 grams.
4. Check needle height and readjust if necessary.

FIELD SERVICE ENGINEERING

# SERVICE BULLETIN

**AUTOMATIC MUSIC, INC.**

# AMi

1500 UNION AVENUE, S. E., GRAND RAPIDS 2, MICHIGAN • TELEPHONE CHERRY 3-3633

May 1, 1961

## BULLETIN NO. 189

**Subject: Instructions for using Stereo Cartridge with a  
Monaural Amplifier**

1. Remove the monaural cartridge and install the stereo cartridge.
2. Unsolder the pin terminals from the tone arm cable and replace with the clip terminals packed with the stereo cartridge. The "R" terminal and the "L" terminal on the cartridge should be connected together and both connected to the red wire in the phono cable. The remaining two terminals should be connected together and connected to the black wire in the phono cable. Thus each of the two wires in the phono cable should have two clip terminals soldered to it. The shield on the stereo cartridge should not be grounded at the terminals just as the shield is not grounded at the terminals on the monaural cartridge.
3. Check stylus force after the stereo cartridge is installed to see that it is between 5 and 7 grams.
4. Check needle height and readjust if necessary.

FIELD SERVICE ENGINEERING

# AUTOMATIC MUSIC, INC.

1500 UNION AVENUE. S. E., GRAND RAPIDS 2, MICHIGAN • TELEPHONE CHERRY 3-3633

# AMI

AFFILIATE OF AUTOMATIC CANTEN COMPANY of AMERICA

May 12, 1961

Dear Sirs:

This CONTINENTAL 2 complete service manual and parts catalog is for insertion into your Service Information Binder, book 1a.

It may be inserted as a complete section, following the entire present contents, or it may be separated by sections and inserted after the proper tabbed dividers.

Also enclosed is a new index for your entire Service Information Binder, book 1a. This index shows the tabbed divider subject matter and its location in the book. This index will also list the sections included in your new Continental 2 manual and where the individual sections should be located if you want to separate them.

More pages will be coming - in particular, additional information for the Continental 2, 100 selection models and the monaural sound system.

As stated in the manual foreword; individual pages will be issued in the event of revision or for supplemental information as the need arises.

Another very important and useful publication included here is a copy of our NEW SALES CATALOG which illustrates ALL phonographs, equipment and accessories currently offered by AMI. This book also gives all specifications for each item listed. This SALES CATALOG (SC-1) is standard 3-hole drilled. The two stitches holding it together may be easily removed and the book inserted either in the Auxilliary Equipment section or as the last item in the binder for easy reference. This, too, is loose-leaf and will be supplemented, on an individual page basis as the need arises.

As a holder of our service binder, you will automatically receive any and all such material - do we have your latest address?

Yours for better service -

Technical Publications -  
Sales Department

# SERVICE BULLETIN

**AUTOMATIC MUSIC, INC.**

# AMi

1500 UNION AVENUE, S. E., GRAND RAPIDS 2, MICHIGAN • TELEPHONE CHERRY 3-3633

May 15, 1961

BULLETIN # 190

## PF-187 REPLACEMENT PARTS GROUP FOR THE AUTO MIX

We can no longer supply the F-10379 sensing switch nor the F-10378A switch lever used on the first production run of Auto Mixes.

A group of parts consisting of a new switch, switch lever, mounting bracket, hardware, and instructions has been prepared for use when it is necessary to replace either of the above mentioned original parts. This parts group should be ordered under the number PF-187.

FIELD SERVICE ENGINEERING

# SERVICE BULLETIN

## AUTOMATIC MUSIC, INC.

1500 UNION AVENUE. S. E., GRAND RAPIDS 2, MICHIGAN • TELEPHONE CHERRY 3-3633

# AMI

AFFILIATE OF AUTOMATIC CANTEEN COMPANY of AMERICA

May 15, 1961

### BULLETIN # 190

#### PF-187 REPLACEMENT PARTS GROUP FOR THE AUTO MIX

We can no longer supply the F-10379 sensing switch nor the F-10378A switch lever used on the first production run of Auto Mixes.

A group of parts consisting of a new switch, switch lever, mounting bracket, hardware, and instructions has been prepared for use when it is necessary to replace either of the above mentioned original parts. This parts group should be ordered under the number PF-187.

FIELD SERVICE ENGINEERING

# SERVICE BULLETIN

## AUTOMATIC MUSIC, INC.

1500 UNION AVENUE, S. E., GRAND RAPIDS 2, MICHIGAN • TELEPHONE CHERRY 3-3633

# AMI

AFFILIATE OF AUTOMATIC CANTEEN COMPANY of AMERICA

May 15, 1961

### BULLETIN # 190

#### PF-187 REPLACEMENT PARTS GROUP FOR THE AUTO MIX

We can no longer supply the F-10379 sensing switch nor the F-10378A switch lever used on the first production run of Auto Mixes.

A group of parts consisting of a new switch, switch lever, mounting bracket, hardware, and instructions has been prepared for use when it is necessary to replace either of the above mentioned original parts. This parts group should be ordered under the number PF-187.

FIELD SERVICE ENGINEERING

# SERVICE BULLETIN

## AUTOMATIC MUSIC, INC.

1500 UNION AVENUE, S. E., GRAND RAPIDS 2, MICHIGAN • TELEPHONE CHERRY 3-3633

AFFILIATE OF AUTOMATIC CANTEEN COMPANY of AMERICA

# AMI

August 14, 1961

### SERVICE BULLETIN # 191

**Subject:** Noise suppression in the CONTINENTAL 2 phonograph.

To eliminate extraneous noises from the sound system in the CONTINENTAL 2, some minor circuit changes are being made. These changes are:

1. Connecting .02 MFD disc ceramic capacitors across each coin switch. These capacitors will be mounted directly on the coin switch assembly.
2. Providing time delay for the amplifier muting relay. The time delay components, a 100 MFD electrolytic capacitor in series with a 100 ohm resistor, are mounted in the record changer control box along with the reversing relay and DC switch.

This change requires an additional set of normally open contacts on the reversing relay and a revision of the record changer wiring harness. Interchanging early and new components will give the following results:

A new record changer control box used on a record changer wired with an early harness will work, but this combination will not provide the desired time delay for the muting relay.

An old record changer control box used on a record changer wired with a new harness will make the popularity meter inoperative and will not provide the desired time delay for the muting relay. Everything else in the phonograph will function normally.

3. Bypassing the 5500 ohm, 10 watt resistor in the amplifier power supply filter section with a .047 capacitor.

Changes 1 and 3 listed above are already in effect. Change 2 will go into effect on about August 14. Corrected schematic charts showing these changes will be included with each phonograph at that time.

*Cliff L. Bitting*  
Cliff L. Bitting  
Field Service Engineering

CLB:emc

# SERVICE BULLETIN

## AUTOMATIC MUSIC, INC.

1500 UNION AVENUE, S. E., GRAND RAPIDS 2, MICHIGAN • TELEPHONE CHERRY 3-3633

# AMI

AFFILIATE OF AUTOMATIC CANTEEN COMPANY of AMERICA

August 14, 1961

### SERVICE BULLETIN # 192

**Subject:** New Speaker Dividing Network for the CONTINENTAL 2.

A new speaker dividing network - part number L-2722B is being incorporated into the CONTINENTAL 2.

This new network and a change in the speaker connections gives the CONTINENTAL 2 more pronounced bass while maintaining wide stereo separation.

Phonographs equipped with the new network can be identified by a label attached to floor of the amplifier compartment. The label reads:

#### NOTE

L-2722B SPEAKER DIVIDING NETWORK INSIDE. FOR SPEAKER CONNECTIONS USE CHART F-10571-D ONLY.

Revised speaker connection charts and amplifier schematics will be included in each phonograph.

*C. L. Bitting*  
Cliff L. Bitting  
Field Service Engineering

C.L.B:amc



# SERVICE BULLETIN

## AUTOMATIC MUSIC, INC.

1500 UNION AVENUE, S. E., GRAND RAPIDS 2, MICHIGAN • TELEPHONE CHERRY 3-3633

# AMI

AFFILIATE OF AUTOMATIC CANTEEN COMPANY of AMERICA

October 9, 1961

### SERVICE BULLETIN #193

Subject: PF-189 Turntable Idler and Link Assembly.  
Replacement for F-898 Idler pulley.

The F-898 turntable idler pulley used on Models F through CONTINENTAL 1 is no longer available. In its place we will furnish a PF-189 turntable idler and link assembly.

This assembly consists of an F-8006A idler - as used on the CONTINENTAL 2 - and a link which will adapt it for mounting on the earlier turntables.

Cliff L. Bitting  
FIELD SERVICE ENGINEERING

CLB:emc

# SERVICE BULLETIN

## AUTOMATIC MUSIC, INC.

1500 UNION AVENUE. S. E., GRAND RAPIDS 2, MICHIGAN • TELEPHONE CHERRY 3-3633

# AMI

AFFILIATE OF AUTOMATIC CANTEEN COMPANY of AMERICA

October 25, 1961

### SERVICE BULLETIN #194

Subject: Operation of monaural 8 ohm extension speakers with  
CONTINENTAL 2 STEREO ROUND phonographs.

Eight ohm speakers can be used to provide monaural or center channel sound from a CONTINENTAL 2 phonograph in areas not covered by the phonograph itself. The 8 ohm speakers must be connected between terminal 5 of the basic amplifier (left channel) and terminal 5 of the add-on power amplifier (right channel). This will provide 4-1/2 watts to each speaker so connected (2-1/4 watts from each channel).

The number of 8 ohm monaural speakers that can be connected depends upon the power setting of the STEREO ROUND speaker system in the phonograph and the power setting of other monaural or stereo extension speakers that are connected to the amplifier. The total power settings of all speakers connected to the amplifier must not exceed 20 watts per channel or 40 watts total.

Note: To avoid excessive power loss, lines connecting 8 ohm speakers must not exceed 100 feet. This will give a 15% power loss for 18 guage wire. If more than one speaker is connected to the line, the length should be reduced proportionally.

*Cliff L. Bitting*  
Cliff L. Bitting  
Field Service Engineering

CLB:emc

**IMPORTANT****ROWE AC SERVICES**Division of Automatic Canteen Company of America  
18 South Michigan Avenue, Chicago 3, Illinois**S E R V I C E****INFORMATION**June 29, 1962  
BULLETIN #195Rowe AMI Phonograph (JAL-200) Revised and Supplement Manual Pages

The attached new pages are for insertion into your Rowe AMI phonograph manual. If you have the Rowe A C Service Information Binder, Book III, simply follow the insertion instructions found in the foreword letter (1st page) and insert these pages, as per page number, into the proper part of the Rowe AMI phonograph manual sections.

Please note that the first REPLACEMENT page is a revised last page of the service manual section "Table of Contents." This Table of Contents revision will tell you which of the other pages should REPLACE old pages and which should be ADDED to existing pages. Use this as insertion instructions and then insert it in place of the old Table of Contents 4th page.

The following is a summary of subject matter covered in this new material:

- SM-3 Changed because of mechanism hold-down refinements. (Same information contained in UNPACKING INSTRUCTIONS in phonograph.)
- SM-13 Additional phonograph lamp replacement information.
- SM-15 & 16 PERSONALIZATION LETTERS installation and ordering information.
- SM-104A, B, C & D (2 sheets) CDA and CDD Steppers Installation Instructions (Same information as included with steppers.)
- SM-130A & B Premium Pricing Information
- SM-130C 50 Cent Relay Unit Information
- SM-139 & 140 Power Amplifier and Control Amplifier schematics revisions (in effect since start of production) reprinted larger for better legibility.

Note: Conversion kit number 400-02590 (L-2590) for converting your Rowe AMI phonograph from 200 selections to 160 or 100 selections is available. This kit includes installation instructions, number F-9856, which is not adaptable, at this moment, to a manual page supplement. This information will be mailed to you, as a permanent manual supplement, as soon as we can adapt it to this form. It is to your advantage to note that a highly decorative panel, 400-02597 (L-2597), is an important part of this kit and necessary for placement in the upper title rack section when converting to 100 selection operation.

**FACTORY;****ROWE AC MANUFACTURING**

Grand Rapids Plant

Division of Automatic Canteen Company of America  
1500 Union Avenue, S. E., Grand Rapids 2, Michigan

- PARTS SECTION -

The following revisions in the parts catalog section are offered as an aid in ordering parts more correctly. Pages PC-16 & 17; Plate #7 and PC-64 & 65; Plate #10 are revised and included here to replace the old pages. The balance of the revisions listed here were not extensive enough to warrant reprinting of the affected pages. However, if this information is recorded on the affected pages in your catalog, some inconvenience to you, and our service parts department, which would result from an incorrect parts order, will be avoided.

<u>Page No.</u>	<u>Plate No.</u>	
PC-7	2	Item #3 (F-9587 Gasket) replaced by: 711-02103 (S-2103K) . . . . . 2 and 712-02103 (S-2103L) . . . . . 2
PC-9	3	Item #20 (F-9569 Gasket) replaced by: 708-02103 (S-2103H) . . . . . 2 710-02103 (S-2103J) . . . . . 2 Added: 300-03822 (H-3822) Top Talent Tunes Display Panel
PC-13	5	Item #17 (F-10896 Spring) should be: 200-09607 (F-9607) Spring . . . . . 1 Item #25 (F-9805 Capacitor) replaced by: 200-11330 (F-11330) capacitor 4.25 MFD 25V N. P. . . . . 1 Item #26 (S-113L resistor) Eliminated.
PC-16 and PC-17	7	Record Changer Mechanism & Trim Changes.  (replacement pages furnished)
PC-19	8	Item #5 (H-2349A Cash Box) replaced by: 301-03824 (H-3824A) Cash Bag Item #24 (F-9767 Seal Bracket) replaced by: 200-11309 (F-11309) Seal Bracket. . . . . 2 NOTE: Index Nos. 4 and 23 on illustration are reversed.
PC-21	9	Item #3 (F-7688 - Alternate Cord and Plug) replaced by: 200-09873 (F-9873) Cord & Plug

<u>Page No.</u>	<u>Plate No.</u>	
PC-23	10	Item #2 (H-3729A Cash Box Enclosure) replaced by: 301-03825 (H-3825A) Cash Box enclosure Item #14 (L-2522A Lower Coin Chute) replaced by: 300-03827 (H-3827) Chute & Pad Assembly Item #19 (F-9851 Pin) replaced by: 200-11311 (F-11311) Pin Item #30 (S-1430D Snap ring) Eliminated
PC-26 and PC-27	12	The mechanism tie-down devices shown here are indicative of earlier models. This method has been improved in current production models. The earlier version can be brought up to current production standards by means of a mechanism stabilizer kit (part number PF-206) which is available from the factory. An instruction sheet (PF-207) is furnished with the kit.
PC-31	13	Item #19 (F-10581 Schematic) replaced by: 200-09732 (F-9732) Remote Control Box schematic Item #24 (H-3033 Potentiometer) replaced by: 300-03769 (H-3769) Potentiometer
PC-33	14	Item #5 (F-7953 Terminal Strip) replaced by: 200-11315 (F-11315) Binding Post Assembly H-3772A Terminal Strip replaced by: 300-03819 (H-3819) Terminal Strip. <u>DELETE:</u> S103S Resistor S107F Resistor S-102D Resistor S-222S Capacitor <u>ADD:</u> 711-00102 (S102K) Resistor (carbon) 1/2 W 470K 708-00107 (S107H) Resistor (carbon) 1/2 W 1.8 K±5% 701-00222 (S-222A) Capacitor (ceramic disc) .0022 MFD 500V
PC-35	15	Item #4 (F-7954 Terminal Strip) replaced by: 200-11316 (F-11316) Binding Post Assembly <u>DELETE:</u> S-223T Capacitor <u>ADD:</u> 200-08362 (F-8362) Rectifier 719-00222 (S-222S) Capacitor

<u>Page No.</u>	<u>Plate No.</u>	
PC-39	1	Item #33 (F-9524 Cam Pin) replaced by: 200-11317 (F-11317) Cam Pin
PC-49	2	Item #10 (F-10743A Solenoid) replaced by: 203-10743 (F-10743C) Solenoid
PC-51	3	Item B (Screw) is replaced by: 200-11078(F-11078) Machine screw
PC-59	7	Item #16 (H-8000E Relay) replaced by: 303-08001 (H-8001C) Relay
PC-64 and PC-65	10	Diamond Stylus Replacement Information (replacement pages furnished)
PC-67	11	Item #4 (S-500X Cord and Plug) replaced by: 716-00500 (S-500R) Cord and Plug
PC-77	16	Item #15 (F-11003 Bracket) <u>eliminated.</u> (now part of Item #18)

FLIPPER.COM

TECHNICAL PUBLICATIONS DEPARTMENT  
Rowe A C Manufacturing  
Grand Rapids Plant