

PILASTER and/or TRIM CAP LIGHT DIFFUSER REPLACEMENT

TOOLS REQUIRED

- 1 - Short 1/4" Nut Driver
- 1 - 5/16" Nut Driver
- 1 - Phillips Screwdriver

NOTE: All Item references used in this procedure may be found in the Model 1050 Wurlitzer Jukebox Service Supplement, Door Assembly, Interior View, Illustrated Parts List, Page 4D, unless otherwise specified.

To replace the Pilaster in the Model 1050 Wurlitzer Jukebox, perform the following:

1. Remove Fluorescent Lamp (Item 5 and 28).

NOTE: Steps 2 through 6 pertain to the right hand Pilaster only.

2. Remove and retain two Screws securing lower Mounting Bracket and Weld Screw Assembly (Item 2).
3. Remove and retain two Screws securing upper Mounting Bracket and Weld Screw Assembly (Item 14).
4. Remove and retain Keps Nut and Eccentric Spacer (see Item 6) securing Latch Lever and Link Assembly (Item 6) to upper Mounting Bracket and Weld Screw Assembly (Item 14).
5. Disengage Mounting Bracket and Weld Screw Assembly (Item 14) from Latch Lever and Link Assembly (Item 6).
6. Push lower Latch Lever through slot in Door Assembly, raise Latch Lever and Link Assembly (Item 6) to clear frame of Door Assembly, then pull Latch Lever and Link Assembly out and down and remove.
7. Remove and retain Keps Nut securing Cable Clamp and remove Cable Clamp.
8. Remove and retain three Screws securing Color Shield (Item 31).
9. Remove and retain four Screws securing Color Shield Clamp (Item 33), then remove Color Shield Clamp and Color Shield.
10. Remove and retain four Screws (2 each) securing Upper and Lower Pilaster Clamp and Pad Assemblies (see Item 21, Page 2D) and remove Pilaster Clamp and Pad Assemblies.
11. Remove and retain three Screws securing Color Shield Support (Item 32) and Extrusion and Pad Assembly (Item 22, Page 2D), then remove Color Shield Support and Extrusion and Pad Assembly.
12. Remove and retain two Screws securing Lower Side Extrusion (Item 27 or 38, Page 2D) and remove Lower Side Extrusion.
13. Remove Pilaster and Tape Assembly.
14. Install replacement Pilaster and reverse disassembly procedure.

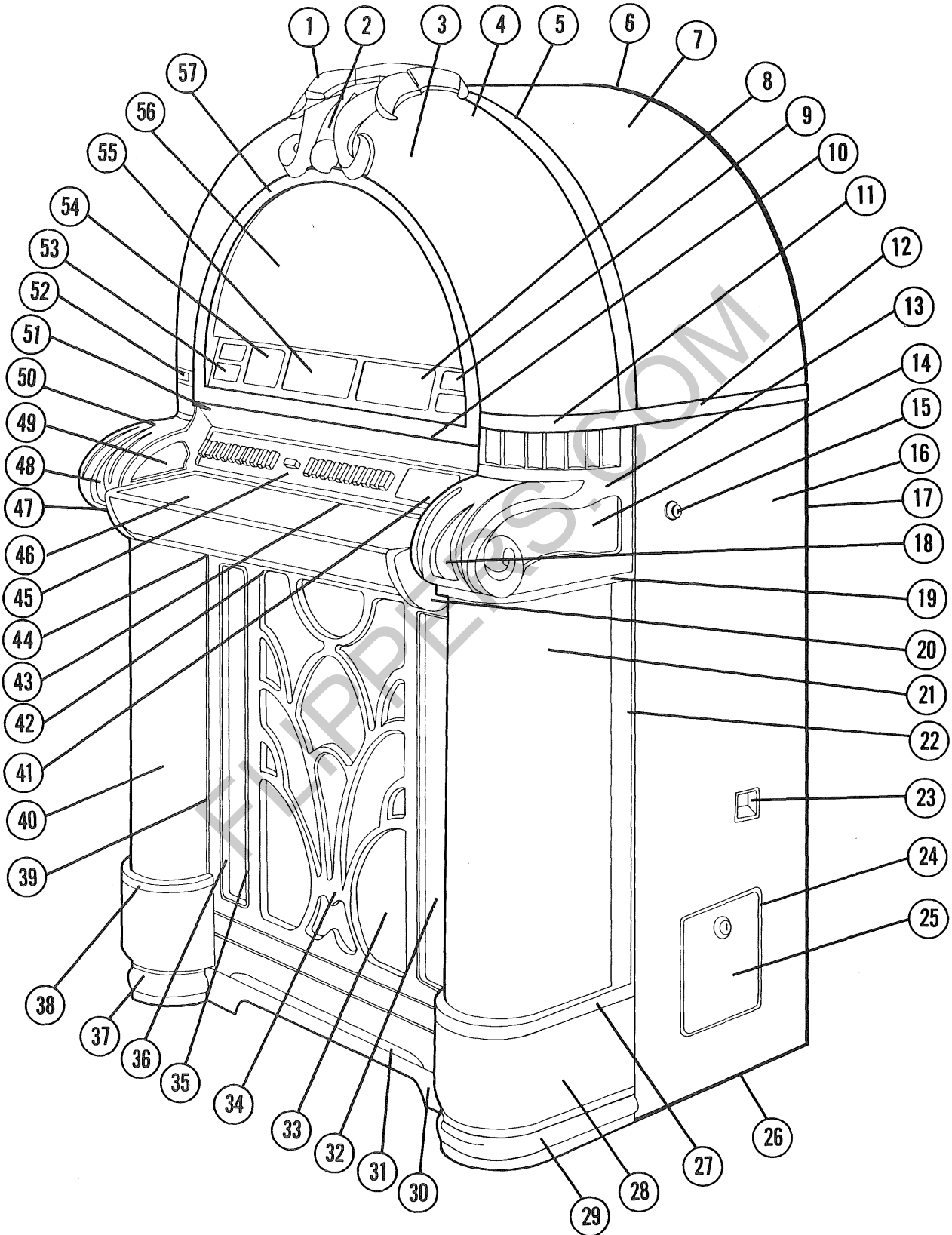

To replace the Upper Trim Cap Light Diffusers, perform the following:

- A. Light Diffuser, Part No. 141891 and 141892 (Blue, Item 49, Page 2D).
 1. Remove and retain Fluorescent Lamp (Item 5 or 28).
 2. Remove and retain 2 Screws securing Upper Light Bracket (Item 26) and cable clamp.
 3. Remove and retain 2 Screws securing 2 cable clamps; remove and retain 3 cable clamps.
 4. Move Upper Light Bracket out of way to provide access to Light Diffuser.
 5. Using either ratchet or short spintite, remove and retain the 4 Screws securing the 2 Upper and 1 Lower Light Diffuser Clamps (Item 49, Page 3D); retain Clamps.
 6. Remove Light Diffuser.
 7. Install new Light Diffuser; reassembly is the reverse of disassembly.
- B. Light Diffuser and Clamp Assembly, Part No. 141947 or 141948 (Amber, Item 18 or 48, Page 2D).
 1. Remove and retain Fluorescent Lamp (Item 5 or 28).
 2. Remove and retain 2 Screws securing Upper Light Bracket (Item 26) and cable clamp.
 3. Remove and retain 2 Screws securing 2 cable clamps; remove and retain 3 cable clamps.
 4. Move Upper Light Bracket out of way to provide access to Light Diffuser and Clamp Assembly (Item 18 or 48, Page 2D).
 5. Remove and retain Screw securing Light Diffuser and Clamp Assembly to Trim Cap.
 6. Using either ratchet or short spintite, remove and retain 2 Nuts securing Light Diffuser and Clamp Assembly to Trim Cap.
 7. Remove Light Diffuser and Clamp Assembly.
 8. Install new Light Diffuser and Clamp Assembly; reassembly is the reverse of disassembly.
- C. Light Diffuser, Part No. 142067 (R.H.) or 142068 (L.H.) (Red, Item 14, Page 2D).
 1. Perform Steps B 1 through B 7.
 2. Using either ratchet or short spintite, remove and retain 4 Screws securing the Top, Front and Lower Light Diffuser Clamps (Item 14, Page 3D); retain Clamps.
 3. Remove Light Diffuser.
 4. Install new Light Diffuser; reassembly is the reverse of disassembly.
 5. Reinstall Amber Light Diffuser and Clamp Assembly; reassembly is the reverse of disassembly.